

High-Frequency High-Efficiency LLC Module with Planar Matrix Transformer for CRPS Application Using GaN Power IC

Bin Li¹, Xiucheng Huang¹, Jason Zhang¹, Tao Wei¹, Justin Zhu¹

¹ Navitas Semiconductor, United States

Corresponding author: Bin Li, bin.li@navitassemi.com

Speaker: Bin Li, bin.li@navitassemi.com

Abstract

To meet the rapidly increasing demand of datacenters, there is a growing need for power supplies with higher power density and efficiency. In this paper, we have constructed a 1.5 kW LLC resonant converter module, which utilizes integrated GaN HEMT ICs from Navitas and fits perfectly within the dimensions of a standard 1U CRPS (90 mm x 30.5 mm x 11 mm). Through leveraging the exceptional performance of the GaN HEMT ICs, we have been able to push the switching frequency to over 600 kHz while maintaining an efficiency of 97.5%. When combined with the industry-leading Totem-Pole PFC, the peak efficiency of the entire system meets the Titanium standard set by 80Plus.

1 Introduction

With the rapid development of cloud computing and the increasing prevalence of Artificial Intelligence, there is a rising demand for datacenters. As high performance multi-core central processing units and graphic processing units become more powerful, their power consumption has become more significant. In 2020, it was estimated that the power consumption of datacenters accounted for 1-1.5% of global electricity use, and this number is projected to increase in the future. Additionally, datacenters were responsible for approximately 300 Mt Co2-eq in 2020, which is equivalent to 0.9% of energy-related Greenhouse Gas (GHG) emissions [1].

Given this situation, two requirements have emerged for the power supply of datacenters in the new era: high efficiency and high power density. High efficiency, especially at light-load or mid-load conditions, can help to reduce energy consumption and associated GHG emissions. Meanwhile, high power density means that more powerful processors can be accommodated within the limited space available in datacenters.

The Common Redundant Power Supply (CRPS) is a widely used standard in datacenters, as defined by Intel. This standard is designed for hyper-converged compute, storage, and networking equipment, and is responsible for converting AC utility

power to 12 V DC power [2]. Fig. 1 illustrates a typical CRPS application.

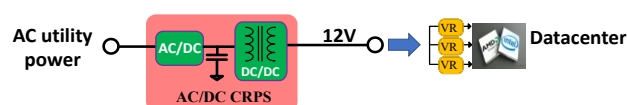

Fig. 1 A typical CRPS application in datacenter.

The most used topology for CRPS is a Boost PFC followed by an LLC resonant converter, as shown in Fig. 2. In the first stage, power factor correction is performed while transferring the AC utility power to a constant 380 V DC bus voltage. The second stage regulates the voltage and provides isolation, converting the 380 V bus voltage to a 12 V low voltage output for the subsequent stages. The Boost PFC operates at a switching frequency of approximately 65 kHz to achieve optimal efficiency and EMI performance, while the LLC resonant converter switches at a frequency of 100 kHz-150 kHz due to the lower switching loss.

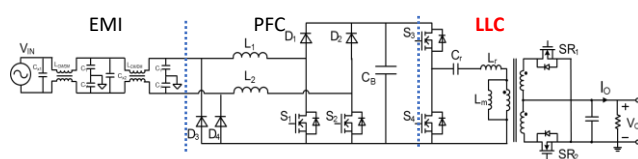

Fig. 2 A typical two-stage topology of CRPS

To regulate the efficiency of CRPS, 80Plus is proposed as a certification program that intended to promote efficient energy use in power supply units, as shown in Table 1 [3]. Currently, the highest standard is Titanium, which requires over 96% at 50% load and over 94% at 20% load.

% of Load	10%	20%	50%	100%
Titanium	90%	94%	96%	91%
Platinum		90%	94%	91%
Gold		88%	92%	88%
Silver		85%	89%	85%
Bronze		81%	85%	81%

Table 1 Efficiency requirement of 80Plus for internal redundant power supply @230V.

Recently, with the emerging wide bandgap power devices, especially gallium nitride (GaN) transistors, the performance of high frequency power conversion is greatly improved. GaN has larger band gap, higher electron mobility and higher electron velocity compared to conventional Si, as shown in Table 2. Thus, better figure of merits can be achieved for GaN High Electron Mobility Transistors (HEMTs), which pushes the switching frequency of power converters to more than five times higher than their Si counterparts while the whole system achieves similar or even higher efficiency [4].

Parameter	Si	SiC	GaN
E_g (eV)	1.12	3.2	3.4
E_{crit} (MV/cm)	0.3	3.5	3.3
Electron Mobility ($\mu\text{ cm}^2/(\text{V}\cdot\text{s})$)	1500	650	990-2000

Table 2 Material properties of Si, SiC and GaN.

One of the benefits of high frequency operation is the significant reduction of the voltage-second across the transformer. In addition, with similar flux density inside the magnetic core, the required number of turns becomes much less, making it possible to use single printed circuit board (PCB) as transformer windings. By adopting this approach, it becomes feasible to achieve a magnetic design that is significantly more condensed, thereby enabling a greater power density. Moreover, utilizing a transformer based on PCB technology enhances the ease of manufacturing and ultimately results in reduced overall system expenses.

In this paper, by using Integrated GaN HEMT ICs from Navitas, a 1.5 kW LLC resonant converter module is built within the size of (90 mm x 30.5 mm x 11 mm), which can be perfectly fit into a standard

1U CRPS. Due to the good performance of Navitas's GaN Power IC, the switching frequency is pushed to over 600 kHz. and still over 97.5% efficiency is achieved. Together with an industry leading 98.5% Totem-Pole PFC, the whole system peak efficiency at 50% can meet the 80Plus's Titanium standard of over 96%.

In Section II, the benefits of Navitas GaN ICs are introduced, as well as their impact on the whole system design, particularly in high frequency operation. Section III presents a novel PCB-based matrix transformer that targets excellent performance with cost reduction to better meet industry needs. The feasibility of the proposed matrix transformer structure is confirmed through 3D finite element analysis (FEA) of both magneto-static and eddy current. A 10-layer PCB is used to build the proposed transformer. The results of experiments verifying the proposed transformer are presented in Section IV.

2 Robust High Frequency Operation using Navitas GaN IC

Due to the superior performance of wide bandgap semiconductor over conventional Si, GaN HEMTs draw a lot of interests and have been widely used in applications where efficiency and power density are of great importance. Commercially, there exist two predominant categories of GaN HEMTs: D-mode GaN HEMTs arranged in a cascode configuration and E-mode GaN HEMTs. D-mode GaN power transistors are normally on devices and a low voltage Si device has to be used in series with it to get a normally off device. On the other hand, E-mode GaN power transistors are naturally normally off devices and are more accepted by the end-user. However, the gate of E-mode GaN HEMTs are relatively fragile compared with conventional Si MOSFET, where the acceptable gate voltage range is -10 V to 20 V and the threshold voltage is 2 V - 5 V. A gate voltage in the range of -10 V - 7 V is widely recommended for steady state operation and the most common threshold voltage is within 1 V - 2 V for E-mode GaN HEMTs [5]. As a result, a very precise gate control is required for E-mode GaN HEMTs.

To address this challenge, various techniques have been proposed. One of the most effective techniques is to have an integrated drivers, which can provide precise control of the gate voltage with fast rise and fall times, reducing the risk of false turn on/off of the device. The integrated drivers also minimize the parasitic inductance/capacitance in the circuit, resulting in reduced ringing and bouncing during switching. In addition, advanced

control algorithms such as dead-time control, adaptive gate drive, and dynamic voltage adjusting have been developed to further improve the performance of GaN HEMTs. These techniques enable E-mode GaN HEMTs to achieve faster switching speeds, higher efficiency, and greater power density, making them more attractive for high-performance power electronics applications. With this in mind, GaN power IC is introduced by Navitas. As the first of its kind, it comes with the industry's leading GaN HEMT and an integrated and customized driver to drive it, as shown in Fig. 3.

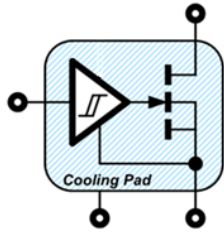

Fig. 3 Block diagram of GaN IC with integrated driver and GaN HEMT.

Through this specific design, Navitas' GaN IC has the capability of "digital in, power out," where the input signal necessitates only a digital high/low signal, while still reliably driving the GaN HEMT inside the IC with the least parasitic and most pristine gate voltage, as illustrated in Fig. 4 [6].

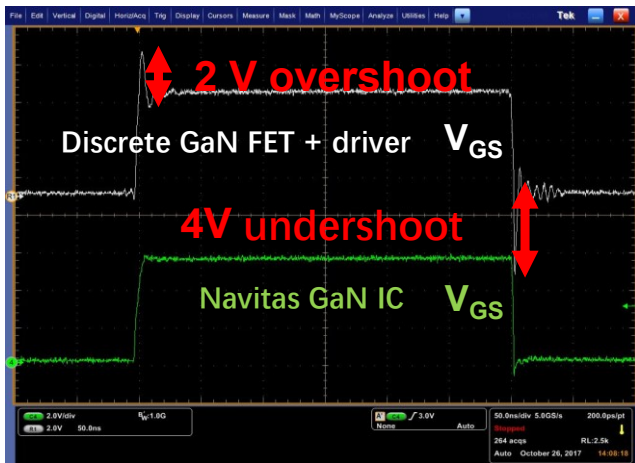

Fig. 4 Benefit of Navitas Integrated GaN IC with clean gate drive voltage.

3 Matrix Transformer Design for LLC

A significant obstacle in utilizing LLC transformers for CRPS applications is the high output current. As a result of the 12 V output voltage, a 1.5 kW power output necessitates a current output of 125

A. Consequently, multiple outputs must be employed to decrease the conduction loss of secondary windings and synchronized rectifiers (SRs).

To determine the optimized number of output sets, a loss calculation is conducted.

The loss of SR consists of three parts, driving loss, conduction loss and body diode conduction loss, which can be represented by Eq. (1)-(3) respectively.

$$P_{dr} = Q_g \cdot f_{sw} \cdot V_{gs} \quad (1)$$

$$P_{cond} = R_{dson}(T) \cdot I_{rms}^2 \quad (2)$$

$$P_{BD} = V_f I_f T_d f_{sw} \quad (3)$$

Where Q_g is the total gate charging; f_{sw} is the switching frequency; V_{gs} is the driving voltage; $R_{dson}(T)$ is the on resistance at junction temperature T ; I_{rms} is the RMS current flowing through SR when gate is on; V_f is the average voltage drop during body diode conduction; I_f is the average current flowing through the body diode and T_d is time during which body diode is conducting.

Using the above equations, we can calculate the total SR loss with different output sets. Here, to fully utilized the space, 40 V MOSFETs from Infineon, IQE013N04LM6 [7] with source down 3x3 package are used.

The outcomes of the calculation are demonstrated in Fig. 5. In the interest of balancing the driving loss, conduction loss, and system cost, while also being mindful of the space limitations on the board, it has been determined that utilizing six sets of output would be the most advantageous option.

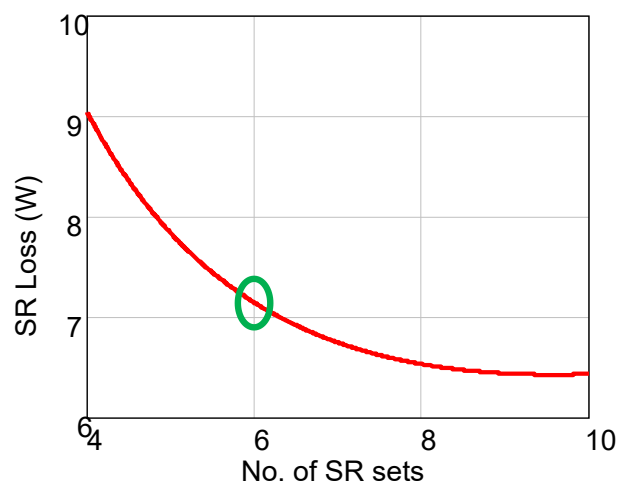

Fig. 5 No. of SR sets selection based on loss.

Upon deciding the number of output sets, the LLC structure can be drawn accordingly, as presented

in Fig. 6. To achieve a higher power density, i.e., to utilize less footprint, two SRs have been incorporated in parallel. As a result of this optimization, the number of output sets has been reduced to three.

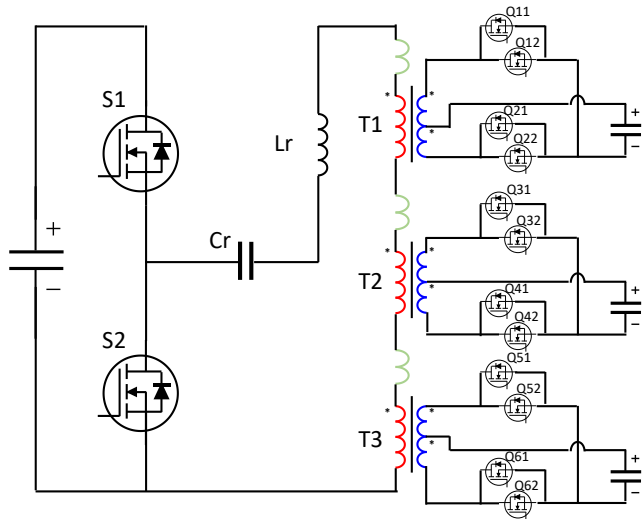

Fig. 6 Proposed half bridge LLC converter.

Traditionally, windings and SRs are paralleled to achieve a lower winding resistance, which results in termination loss. As the switching frequency increases, this type of loss becomes more apparent, leading to a decline in overall system efficiency.

To avoid termination loss, multiple transformers are proposed. Instead of parallel windings and parallel SRs, transformers are paralleled and as a result, the terminals are simplified. In addition, by using this method, interleave between primary and secondary windings improves, especially at the terminations, where windings are connected to SRs. This helps to reduce the AC related conduction loss as well as the leakage flux, resulting in a smaller leakage inductance.

However, multiple transformers also mean larger core loss and magnetic size, as shown in Fig. 7. By adopting the concept of matrix transformer, with flux cancellation between cores, the core volume is reduced, as well as the core loss.

A matrix transformer is a combination of single transformers in a way that the primary side windings are in series/parallel and the secondary side windings are in parallel/series [8, 9]. For step down applications like LLC in CRPS, primary side series and secondary side parallel is suitable. In this case, the desired turns ratio can be calculated by,

$$N = \frac{V_{in}}{2V_o} \quad (4)$$

Where V_{in} is the bus voltage, and its nominal value is 380 V; V_o is the output voltage, which, in CRPS

application, is 12 V. Therefore, the most suitable turns ratio N is 16. However, to accommodate the number of transformers (the turns ratio should be an integer multiple of three), a turns ratio of 15 is selected. Considering using primary side windings in series and secondary side windings in parallel, each transformer needs a turn ratio of five.

Based on the above analysis, a matrix transformer structure is proposed with three sets of output, as shown in Fig. 8. Each core post has been designated to represent one of the output sets, with T1, T2, and T3, as illustrated in Fig. 6.

A novel approach has been implemented wherein the flux in the last core post is purposefully reversed, rather than arranging the flux in each core post to flow in the same direction (as shown in Fig. 7.). By doing so, the flux in the side post can be effectively canceled out, leading to a smaller flux density and reduced core loss, as clearly demonstrated in Fig. 8.

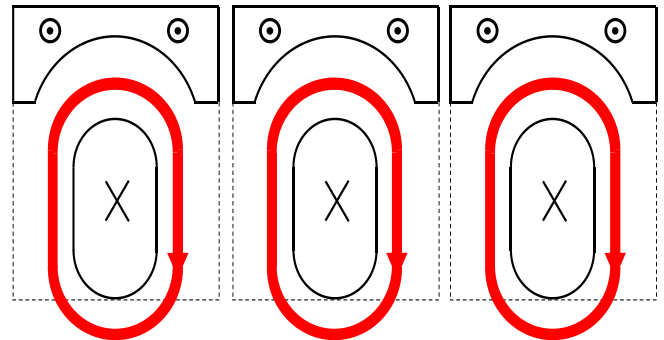

Fig. 7 Three sets of output using single transformers.

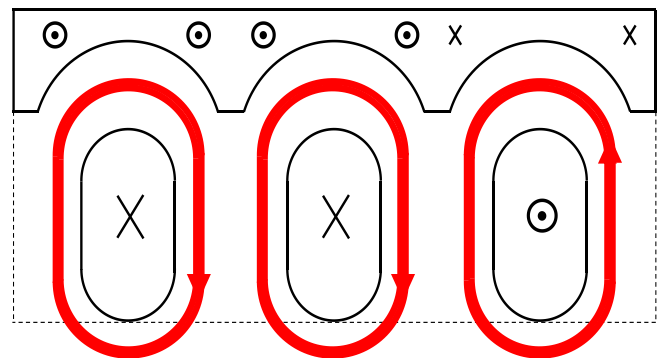

Fig. 8 Three sets of output using matrix transformer and its flux direction.

A 3D FEA simulation model is built based on the proposed transformer structure to simulate the flux distribution in magnetic core as well as current distribution in windings, as shown in Fig. 9.

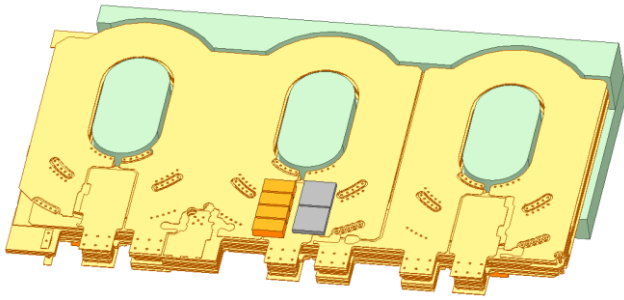

Fig. 9 Proposed matrix transformer structure with three sets of output.

Using this 3D model, the flux distribution within the core can be simulated as well as the inductance/coupling of the transformer. The results are shown in Fig. 10. It can be seen that the flux in the side core post is reduced because of the flux cancellation.

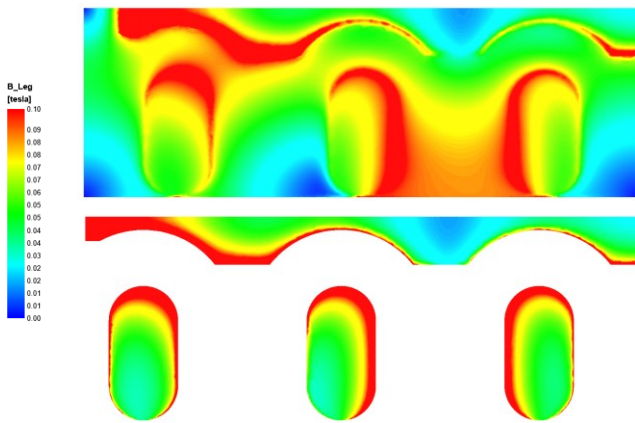

Fig. 10 3D FEA simulation results of flux distribution in core.

By implementing GaN HEMTs, it becomes viable to attain switching frequencies in the range of hundreds of kilohertz or even megahertz, particularly in the case of LLC converters where all switches operate with zero voltage switching (ZVS). The advantage of pursuing high frequency operation is the reduction in size of passive components. Traditional wire-based transformers are cumbersome and entail extensive manual labor, whereas PCB-based planar transformers can be produced with automation, resulting in significantly reduced labor costs and enhanced consistency for large-scale manufacturing. Nonetheless, due to the restrictions of PCB windings, planar transformers can only be achieved when the switching frequency is sufficiently high to substantially decrease the number of turns.

In addition to the advantages offered by the PCB-based matrix transformer, several challenges re-

main, with the most significant being high AC winding loss due to skin effect and proximity effect. Due to the limitations of the PCB, these high-frequency effects can have a significant impact, and the resulting AC loss of the PCB winding can be overwhelming [10].

To overcome this challenge, innovative solutions are required, such as the use of specialized winding arrangement to reduce the impact of the skin and proximity effects. Therefore, while the PCB-based matrix transformer offers many benefits, it is essential to address the challenges associated with high-frequency effects to ensure optimal performance and efficiency.

As a result, a 10-layer PCB is adopted and interleave structure is implemented, as shown in Fig. 11.

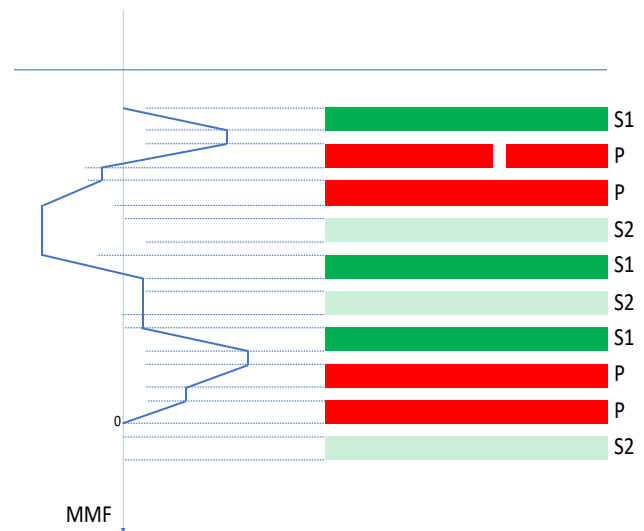

Fig. 11 Winding arrangement and its resulted MMF.

In this configuration, *S1* and *S2* represent the two windings in one center-tap output respectively, and *P* represents the primary side winding. To achieve the designed 5:1 turns ratio, totally 5 turns of primary winding is assigned in 4 layers of PCB (Layer 2/3/8/9), and all of them are in series. While for secondary windings, totally 6 layers of PCB is used and all of them are in parallel to handle the significant secondary current. But it is worth mentioning that during each switching cycle, *S1* and *S2* will both conduct half of the time.

The Magnetomotive Force (MMF) is also drawn on the left side in Fig. 11. The magnitude of MMF indicates the AC current loss and it is clear that by adopting interleave, its magnitude is effectively suppressed and therefore a better winding conduction efficiency is expected.

To better verify the PCB winding design, the AC current distribution within each winding is simulated based on a 3D FEA model, and the results are shown in Fig. 12.

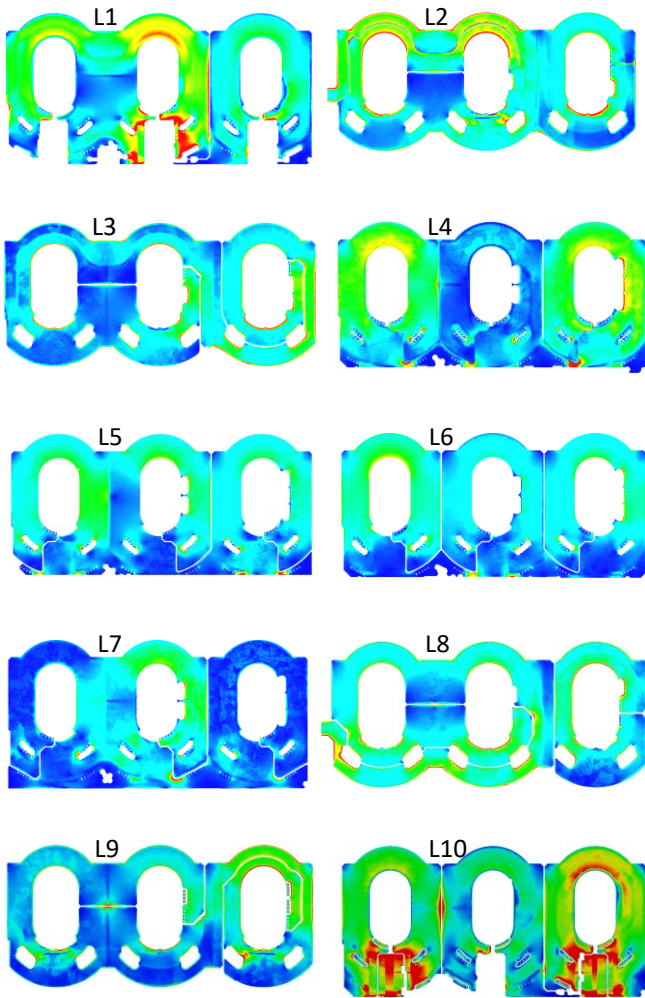

Fig. 12 AC current distribution in each windings.

4 Experimental Verification of the Proposed Matrix Transformer

Based on the designed matrix transformer in section III, an experimental prototype is built, as shown in Fig. 13. (A discrete resonant inductor of 3.5uH is added, which is not shown in the figure.).



Fig. 13 Hardware prototype based on the proposed LLC module using matrix transformer and GaN IC.

The operating waveform of the prototype is depicted in Fig. 14, exhibiting an output power of 1.25 kW.

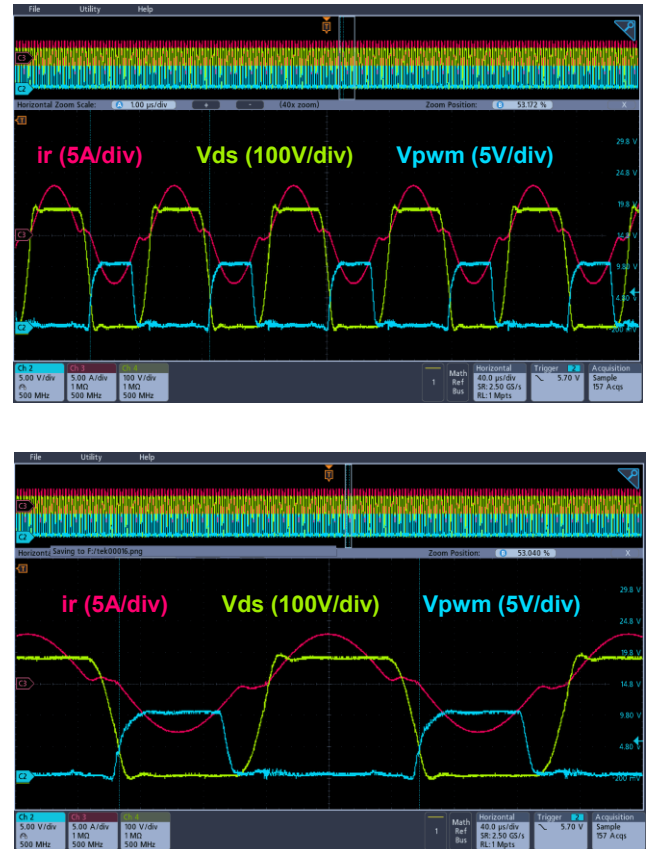

Fig. 14 Working waveforms of the proposed high frequency LLC module.

The preliminary tested module efficiency, as shown in Fig. 15, includes the loss of both the resonant inductor and the auxiliary power supply. To achieve maximum power output, the module must be integrated into the system, and a dedicated thermal management system is required to prevent overheating. Therefore, full power testing will be conducted upon assembly with the entire system.

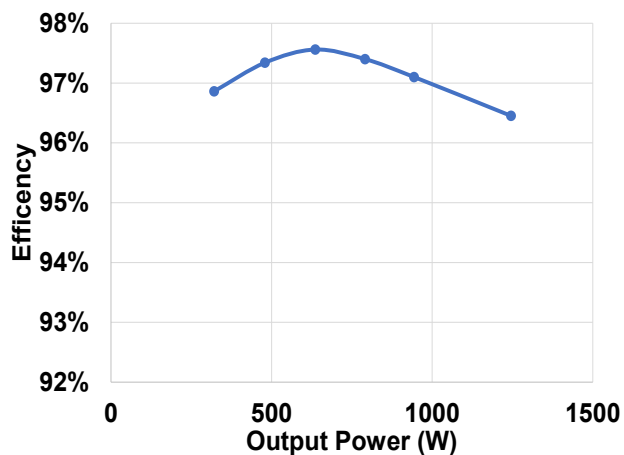

Fig. 15 Tested module efficiency including resonant inductor and aux-power loss.

5 Summary and Conclusion

This paper proposes a compact 1.5 kW LLC resonant converter module that measures 90 mm x 30.5 mm x 11 mm, which is designed to fit perfectly into a standard 1U CRPS. The module is equipped with Integrated GaN HEMT ICs from Navitas, which enable high performance and allow for the switching frequency to be pushed to over 600 kHz. Despite the high frequency, the module still achieves over 97.5% efficiency. The module is paired with industry-leading 98.5% Totem-Pole PFC to achieve a peak efficiency of over 96% at 50%, meeting the 80Plus Titanium standard.

6 Reference

- [1] <https://www.iea.org/reports/data-centres-and-data-transmission-networks>
- [2] Pratt, A., Kumar, P., and Aldridge, T.V., 'Evaluation of 400v Dc Distribution in Telco and Data Centers to Improve Energy Efficiency', in, *Telecommunications Energy Conference, 2007. INTELEC 2007. 29th International*, (2007)
- [3] https://en.wikipedia.org/wiki/80_Plus
- [4] Lidow, A., Strydom, J., Rooij, M.D., and Ma, Y., *Gan Transistors for Efficient Power Conversion*, (Power Conversion Publications, 2012)
- [5] Huang, X., Liu, T., Li, B., Lee, F.C., and Li, Q., 'Evaluation and Applications of 600v/650v Enhancement-Mode Gan Devices', in, *Wide Bandgap Power Devices and Applications (WiPDA), 2015 IEEE 3rd Workshop on*, (2015)
- [6] Stevens, J., Ribarich, T., and Oliver, S., 'Practical Realization of Gan's Capability: Ganfast Power Ics Introduce Lossless Sensing and

Autonomous Protection', *IEEE Power Electronics Magazine*, 2022, 9, (2), pp. 30-38.

[7] https://www.infineon.com/dgdl/Infineon-IQE013N04LM6-DataSheet-v02_00-EN.pdf?fileId=5546d46272e49d2a01735298bd175b06

[8] Reusch, D. and Lee, F.C., 'High Frequency Bus Converter with Integrated Matrix Transformers for Cpu and Telecommunications Applications', in, *Energy Conversion Congress and Exposition (ECCE), 2010 IEEE*, (2010)

[9] Huang, D., Ji, S., and Lee, F.C., 'Llc Resonant Converter with Matrix Transformer', *Power Electronics, IEEE Transactions on*, 2014, 29, (8), pp. 4339-4347.

[10] Li, B., Li, Q., and Lee, F.C., 'High-Frequency Pcb Winding Transformer with Integrated Inductors for a Bi-Directional Resonant Converter', *IEEE Transactions on Power Electronics*, 2019, 34, (7), pp. 6123-6135.