



Executive Summit

USA POWER 2026

The Power Behind AI: Scaling Data Centers for the Future

Power Technologies Enabling the Data Center and AI Revolution

Llew Vaughan-Edmunds

VP & GM, GaN BU

Navitas Semiconductor

April 2026



Healthcare

AI turned years of drug discovery into days, delivering an oral treatment for COVID-19.

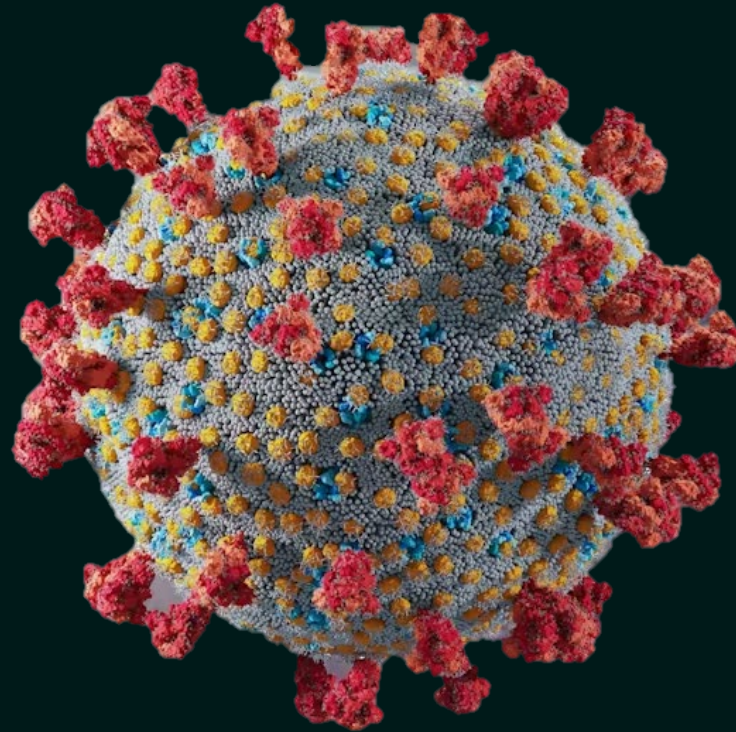

3D model of SARS-CoV-2 virus where **AI targeted** hidden regions of the spike proteins

AI simulated billions of individual molecules that effects the behavior of the SARS-CoV-2 virus (COVID-19), identify viable compounds in days instead of years.

Material Science

Human discovery: 20,000 materials

AI discovery: 2.2 million materials

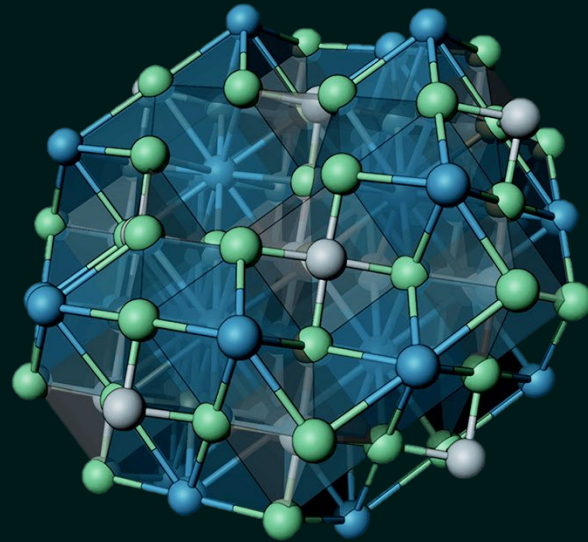

Over 380,000 new materials are considered stable

Barium (blue), niobium (white), and oxygen (green) form a novel type of barium niobate for **next generation electro-optic, ferroelectric, and nonlinear optics.**

Google DeepMind announced GNoME, a cutting-edge AI model that applies graph neural networks to accelerate the discovery of new materials, saving several decades using traditional methods.

Transportation

AI is cutting traffic congestion and CO₂ emissions by over 20%.



Singapore **reduced congestion by 25%**, while Los Angeles **lowered emissions by 21%**

Google's Green Light: This initiative uses AI to map traffic patterns and recommend traffic light timing changes to cities, with trials showing potential for reducing stop-and-go traffic by up to 50%.

AI Demands More Power!

Relative Power Consumption (vs Google Search)

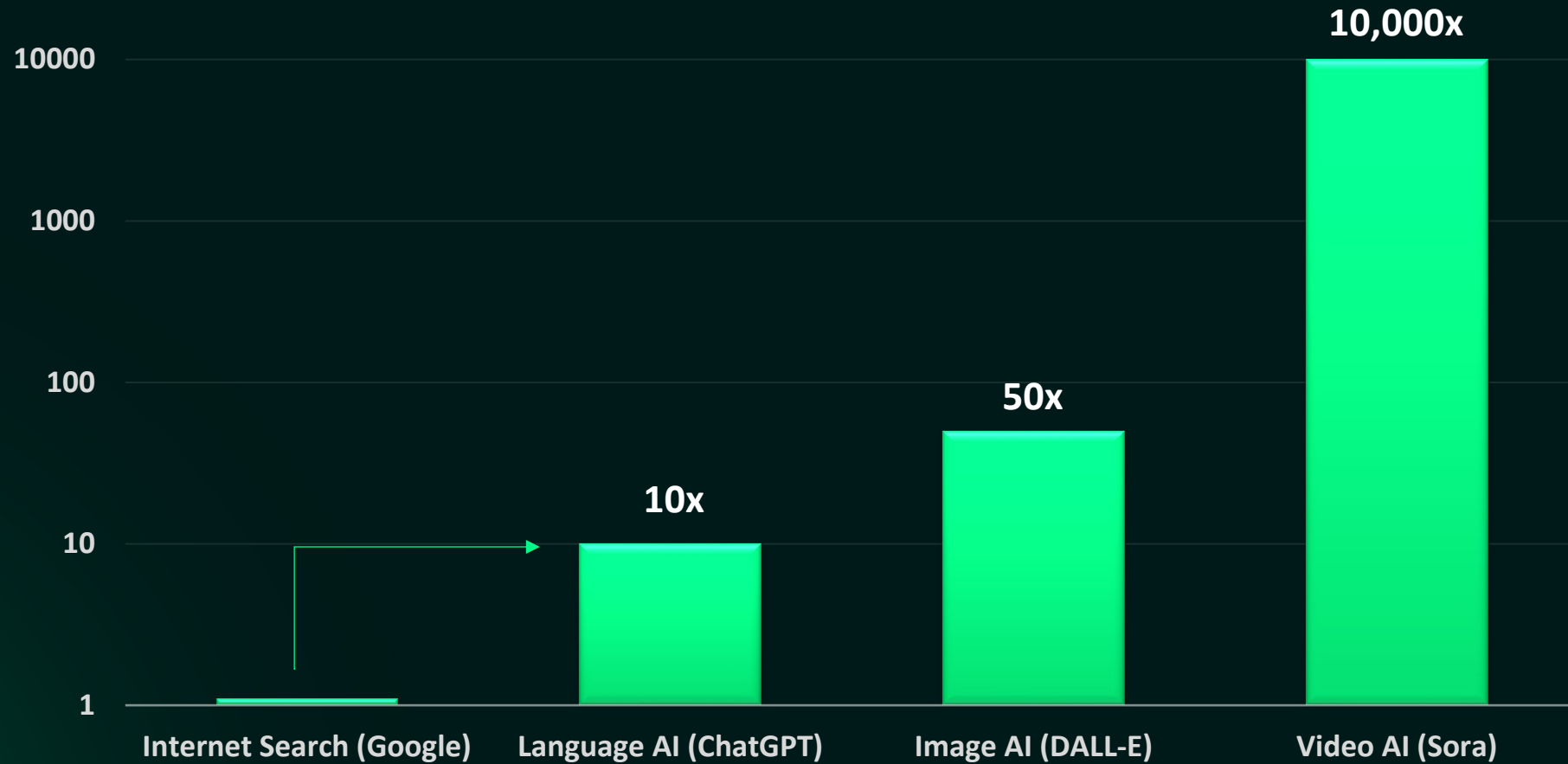

AI Demands More Power!

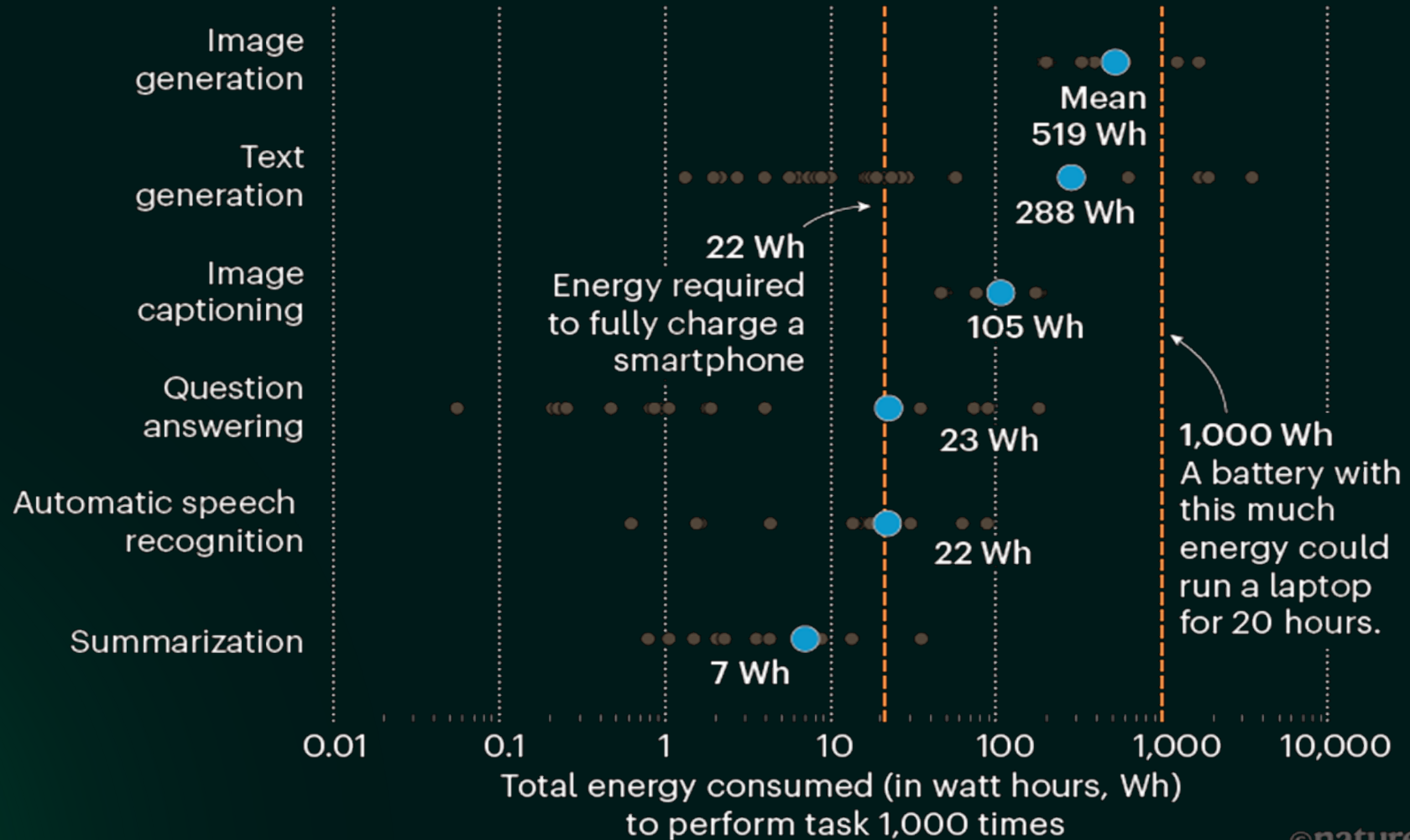

Data Center Power will QUADRUPLE in 10 years

- AI data centers are set to consume >1,500 terawatt-hours of power demand by 2035, equal to 4.4% of global electricity.

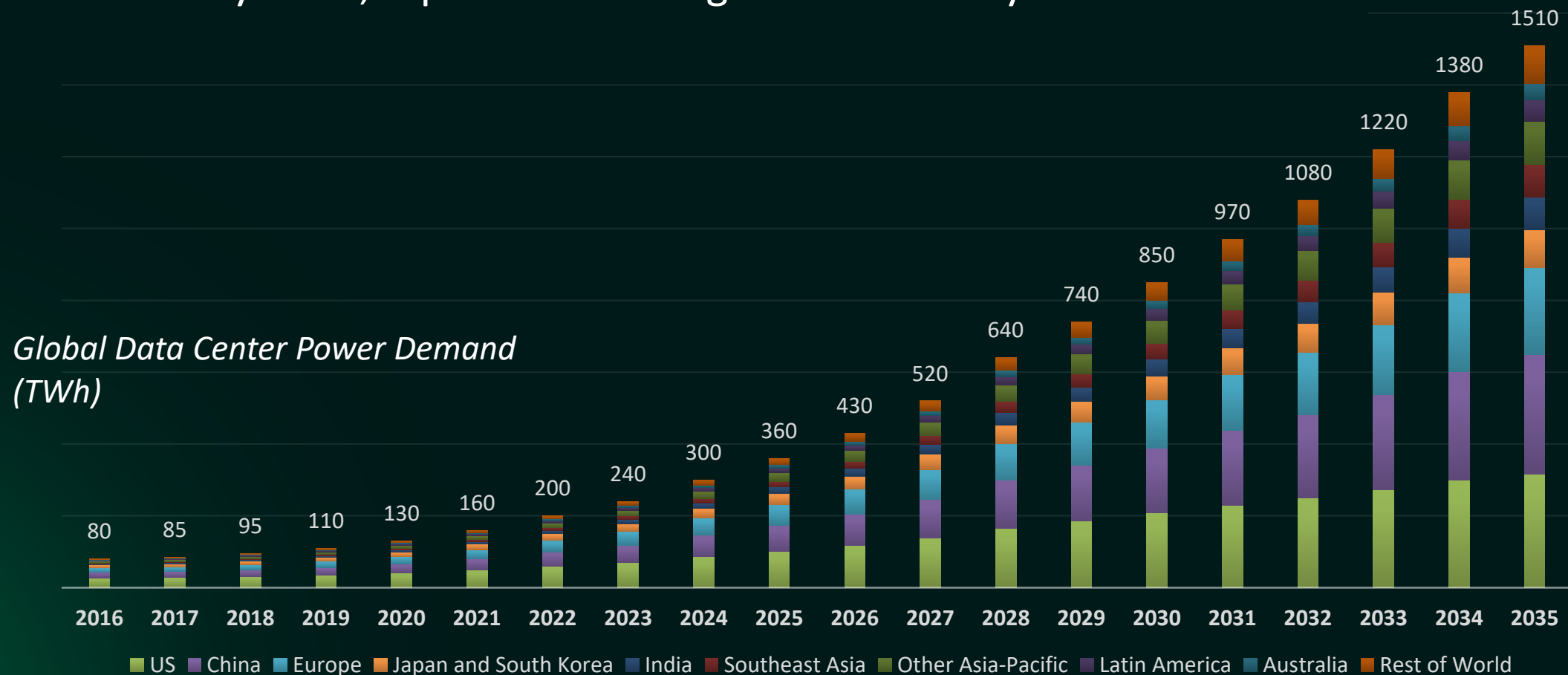

CPU, TPU, GPU Driving More Power

- AI is accelerating the shift to high-performance, accelerated servers, driving data center power demands to new extremes.
- Servers account for ~60% of electricity demand, driven by high-performance xPUs
- Cooling accounts for 20% of total energy consumption

Share of electricity consumption by data center and equipment type

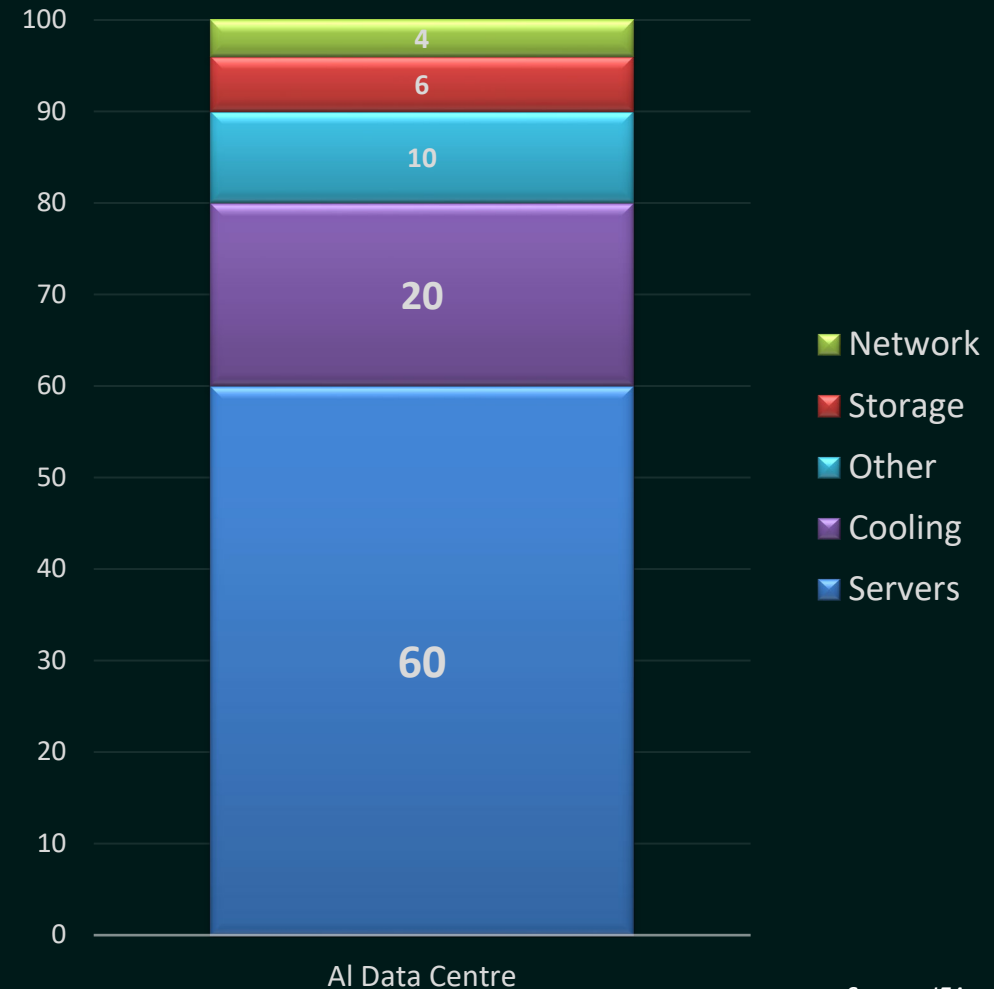

The GPU Power Explosion is Redefining Rack Power

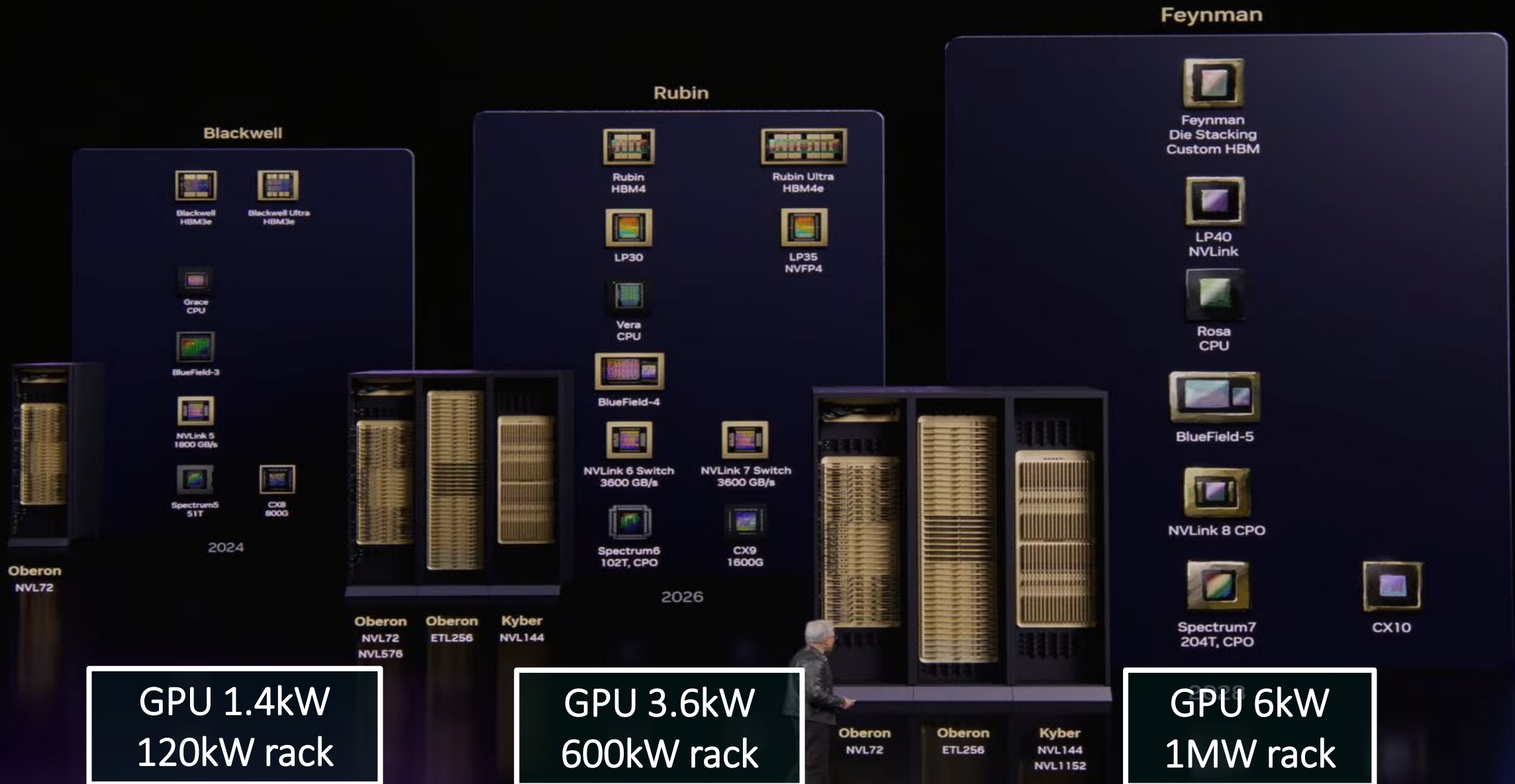

Nvidia AI Server Power Architecture Design Trends

Source: Ming-Chi Kuo (郭明錕), X (<https://x.com/mingchikuo>), Oct 29, 2025.

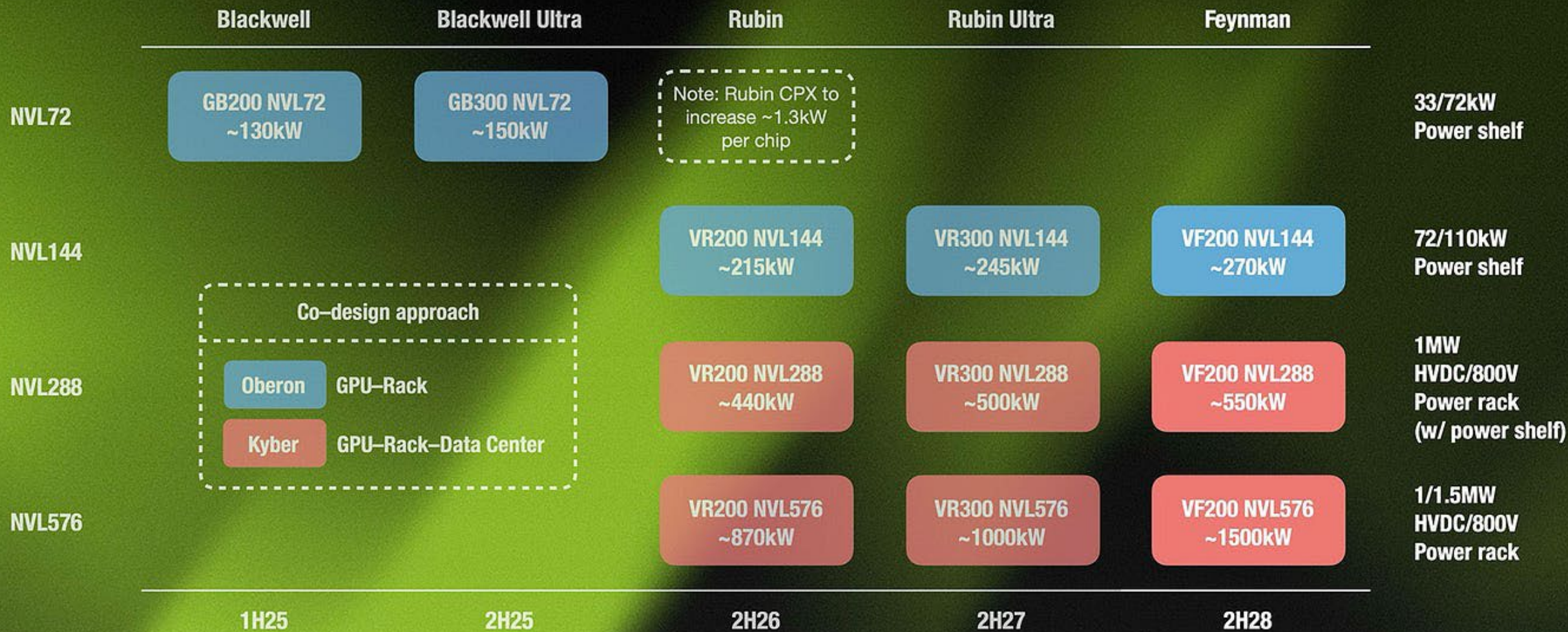

AI Datacenters: Architectural Shift to Multi-MW Racks

 Navitas anchor products / capabilities

Today: Centralized AC with rack level AC-DC conversion

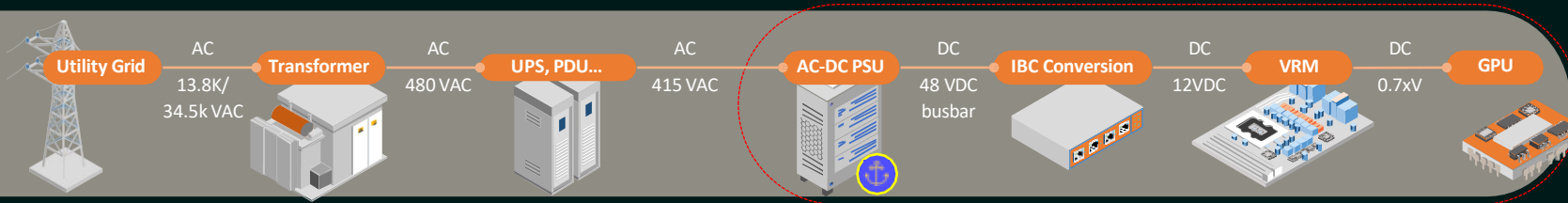

Server Rack: <250kW

Energy efficiency	Typical power tree	Wideband Gap content per MW
80-85%	95+% Silicon-based	-

Short-to Mid-term evolution – 800V HVDC

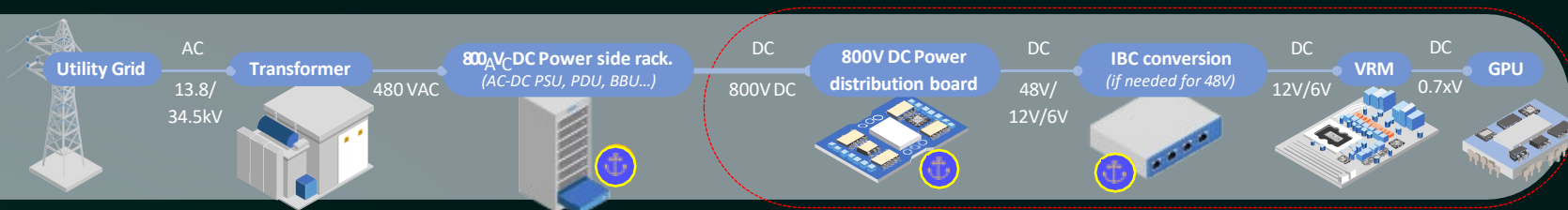

Server Rack: >250kW

Up to 90%	Significant GaN / SiC	\$10K-\$20K
-----------	-----------------------	-------------

Mid- to Long-term evolution – 800V HVDC

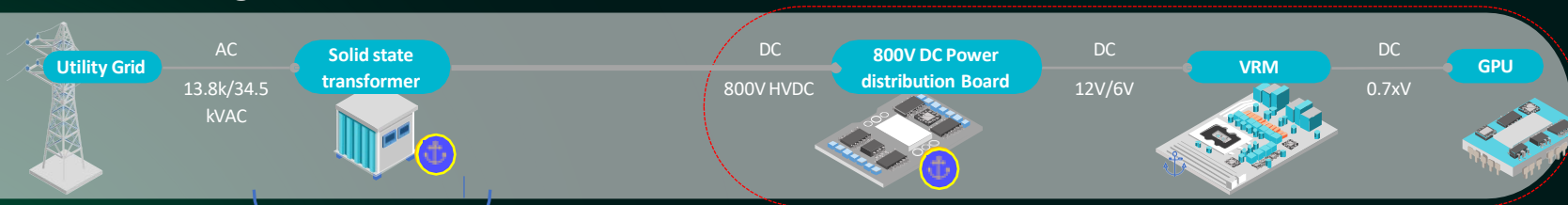

Server Rack: >600kW

Over 90%	Accelerating GaN / SiC	\$25K-\$35K
----------	------------------------	-------------

SSTs to further accelerate demand for MV/HV power semis

Solid-State Transformers Are Redefining Grid Performance

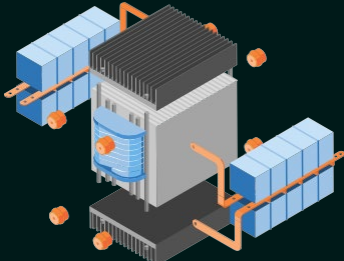
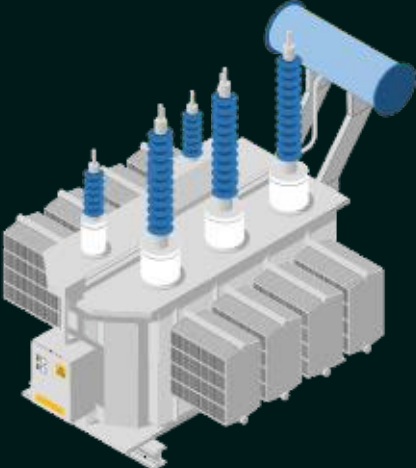

Conventional Transformer

Medium Frequency Isolation Transformer

Figures of merit

Volumetric power density	0.2kW / L	25kW / L
Gravimetric power density	0.5kW / Kg	25kW / Kg
Operating frequency	60Hz	100KHz
Efficiency	< 95%	> 98%
Size	-	20x reduction

800V In-Tray Power Delivery Drives Efficiency & Density

- 10kW DC-DC Brick (800V -50V)
- 98.5% peak efficiency
- 1.9 kW/in³ power density

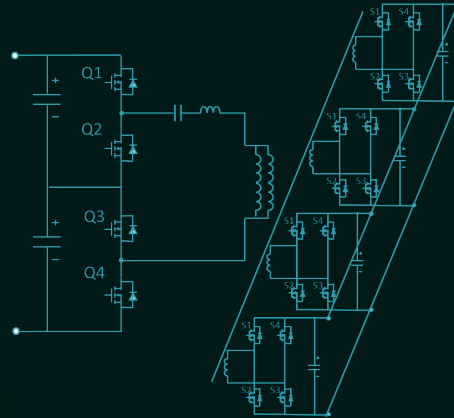
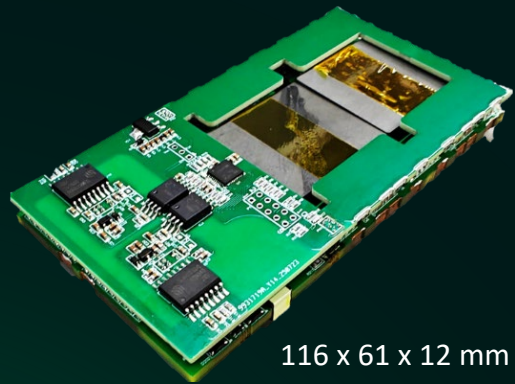

- 20 kW DC-DC PDB (800V – 6V)
- 97.5% peak efficiency
- 2.1 kW/in³ power density
- Displayed by NVIDIA at GTC 2026

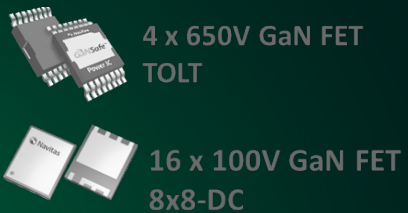
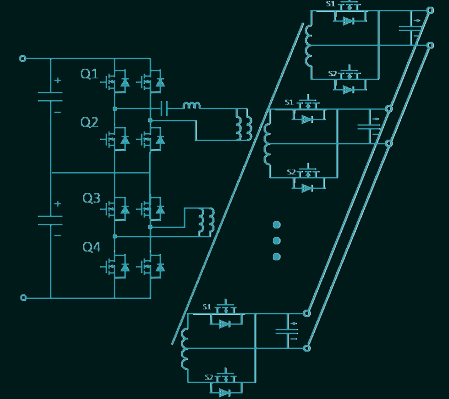
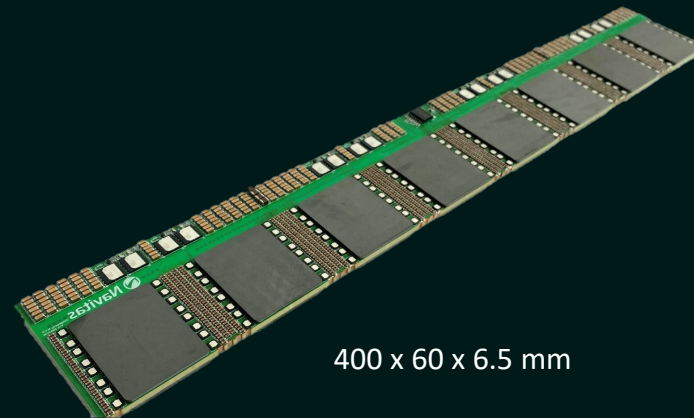

IT Compute Rack Power Delivery Evolution

AC-DC Shelf
 $415V_{AC} - 50V_{DC}$

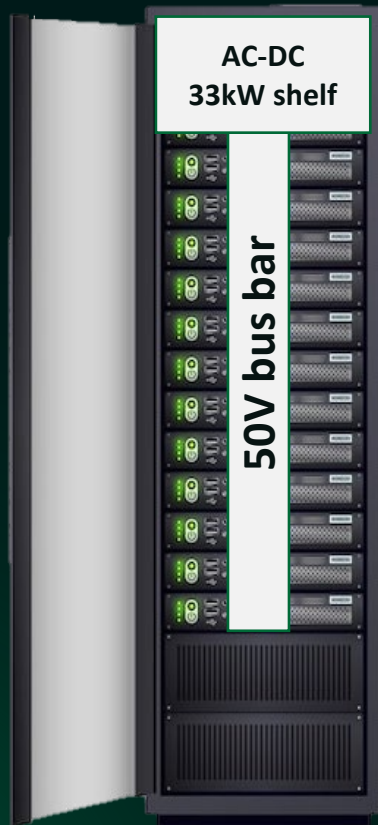

- 1200V SiC
- 650V SiC
- 100V GaN

120 kW per rack

DC-DC Shelf
 $800V_{DC} - 50V_{DC}$



- 650V SiC
- 60V GaN
- 100V GaN

600 kW per rack

DC-DC In-Tray
 $800V_{DC} - 50/12/6V_{DC}$



- 650V GaN
- 100V GaN

1 MW+ per rack

**Only showing IT Compute rack and not Power Sidecar*

Navitas is Powering the Future of Data Centers!

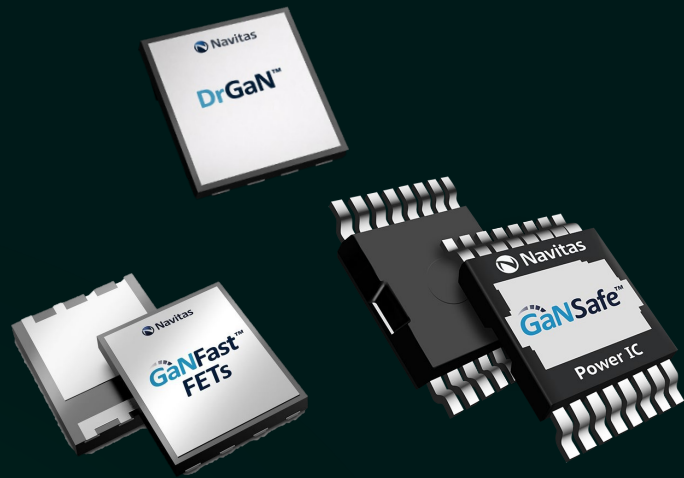

100V – 650V

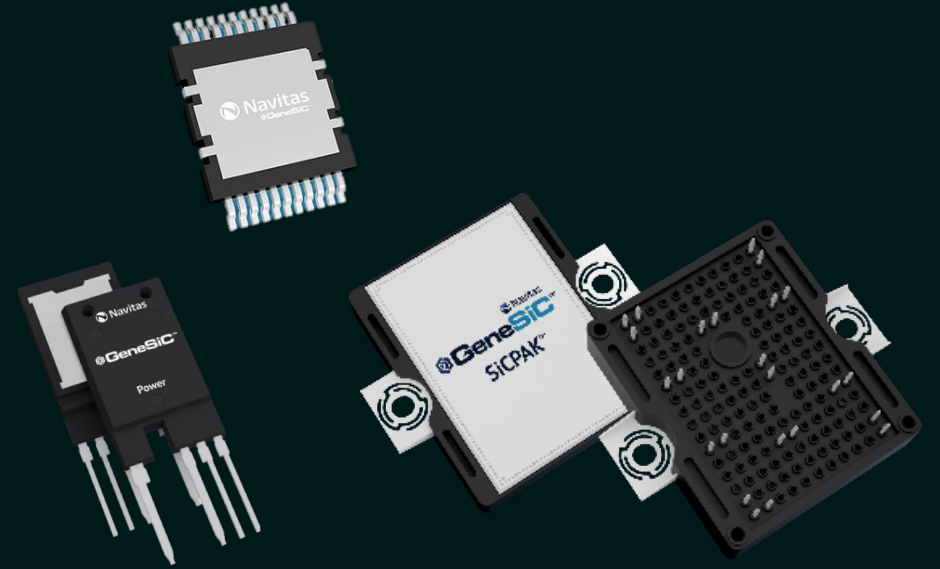

650V – 3,300V

Let's go **GaNFast™**

GeneSiC™ Strong!

Summary

- AI-driven data center demand is rapidly accelerating global power consumption
- Data center energy use is approaching country-scale levels and will continue to grow
- Rack-level power is growing above 1MW to support higher compute loads
- Energy efficiency and power infrastructure innovation are essential to enable sustainable AI scaling
- Navitas' GaN & SiC are enabling the next wave of scalable AI growth.



Executive Summit
USA POWER 2026

Thank you!



www.navitassemi.com



Navitas