



Flyback Sync Rect Controller IC

Features

High Frequency SR Controller

- Compatibility of continuous conduction mode (CCM), quasi-resonant (QR) and discontinuous conduction mode (DCM)
- Compatible with high side and low side application
- Wide input voltage ranges up to 26.5V
- Optimized SR gate turn-off threshold control
- Proprietary CCM SR turn-off control algorithm
- Minimized SR turn-on/off propagation delay
- SR MOSFET gate passive clamp
- Low power saving mode
- Small footprint with SOT-23-6L package

Product Reliability

- 20-year limited product warranty

Topologies / Applications

- USB PD quick chargers for smart phones, feature phones and tablet PCs
- Power adaptor for portable device
- Flyback power supply with fixed or variable output voltage



SOT-23-6L Package

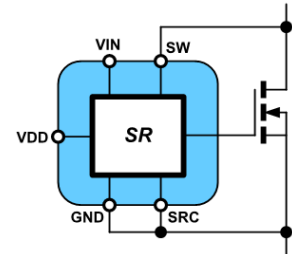

Simplified Schematic

Description

NV9701 is a secondary-side synchronous rectifier (SR) controller for isolated flyback converters. By implementing proprietary turn-off control algorithm, NV9701 can reliably support discontinuous conduction mode (DCM), quasi-resonant (QR) and continuous conduction mode (CCM) operation, which will help to design robust flyback converters. Small footprint SOT-23-6L package enables designers to achieve simple, quick and reliable solutions. Navitas' controller IC technologies enable high frequencies, high efficiencies and low EMI to achieve unprecedented power densities at a very attractive cost structure.

Simplified Application Diagram

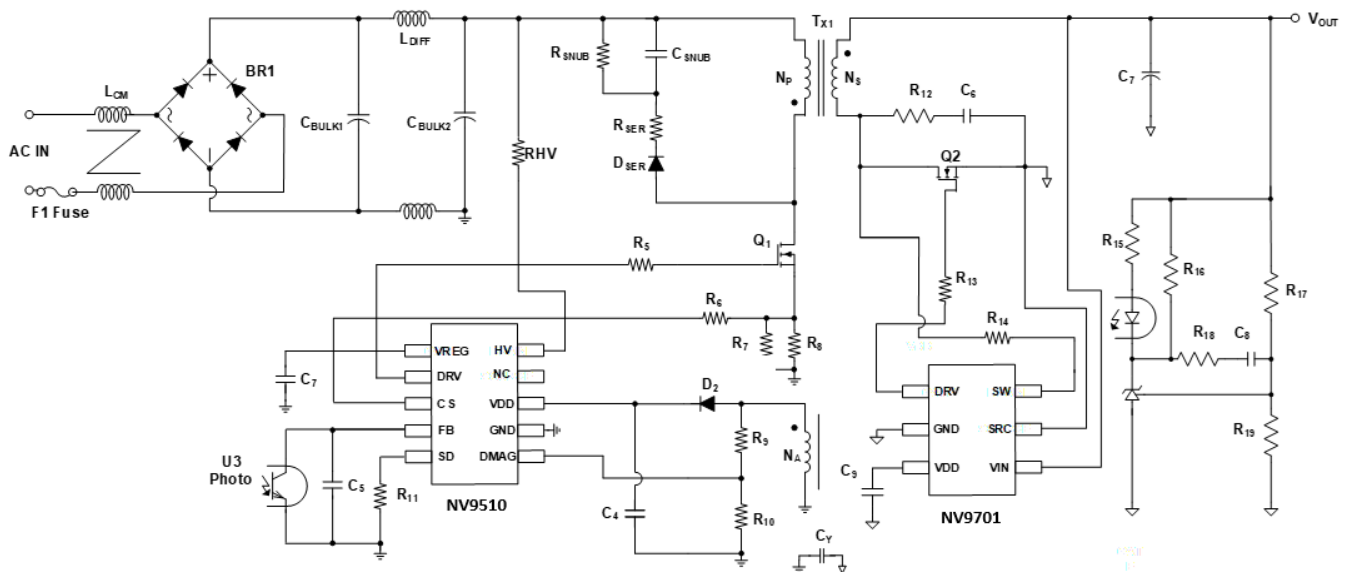

Figure 1. Low-Side SR Application Diagram

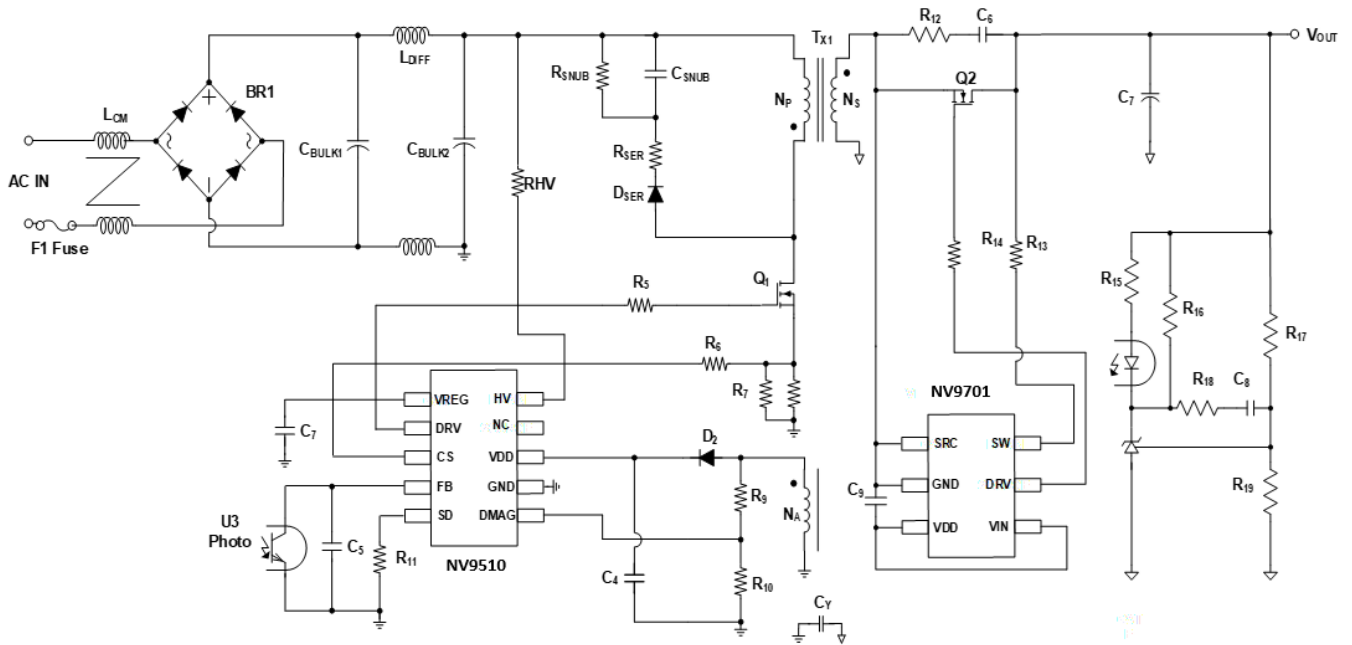

Figure 2. High-Side SR Application Diagram

Ordering Information

Part Number	Operating Temperature Range	Package	Packing Method
NV9701SC01	-40°C to +125°C	6-Lead, SOT23	3K/Tape & Reel

Pin Configuration and Marking Diagram

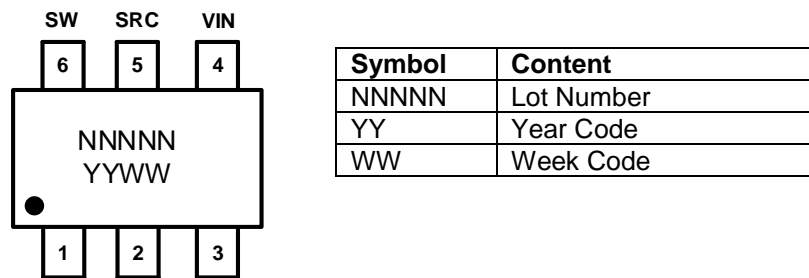

Figure 3. NV9701 Pin Configuration & Marking Diagram (Top View)

Pin Function

Pin No.	Name	Description
1	DRV	Synchronous MOSFET gate drive output.
2	GND	Ground.
3	VDD	Internal regulator 5V output and gate driver power supply rail. Bypass with 1μF capacitor to GND.
4	VIN	Supports up to 26.5V operation, input of an integrated 5V LDO which generates the internal power supply for the low-voltage control circuitry.
5	SRC	Synchronous MOSFET source sense input.
6	SW	Synchronous MOSFET drain sense input.

Table 1. NV9701 Pin Definition

Internal Function Block Diagram

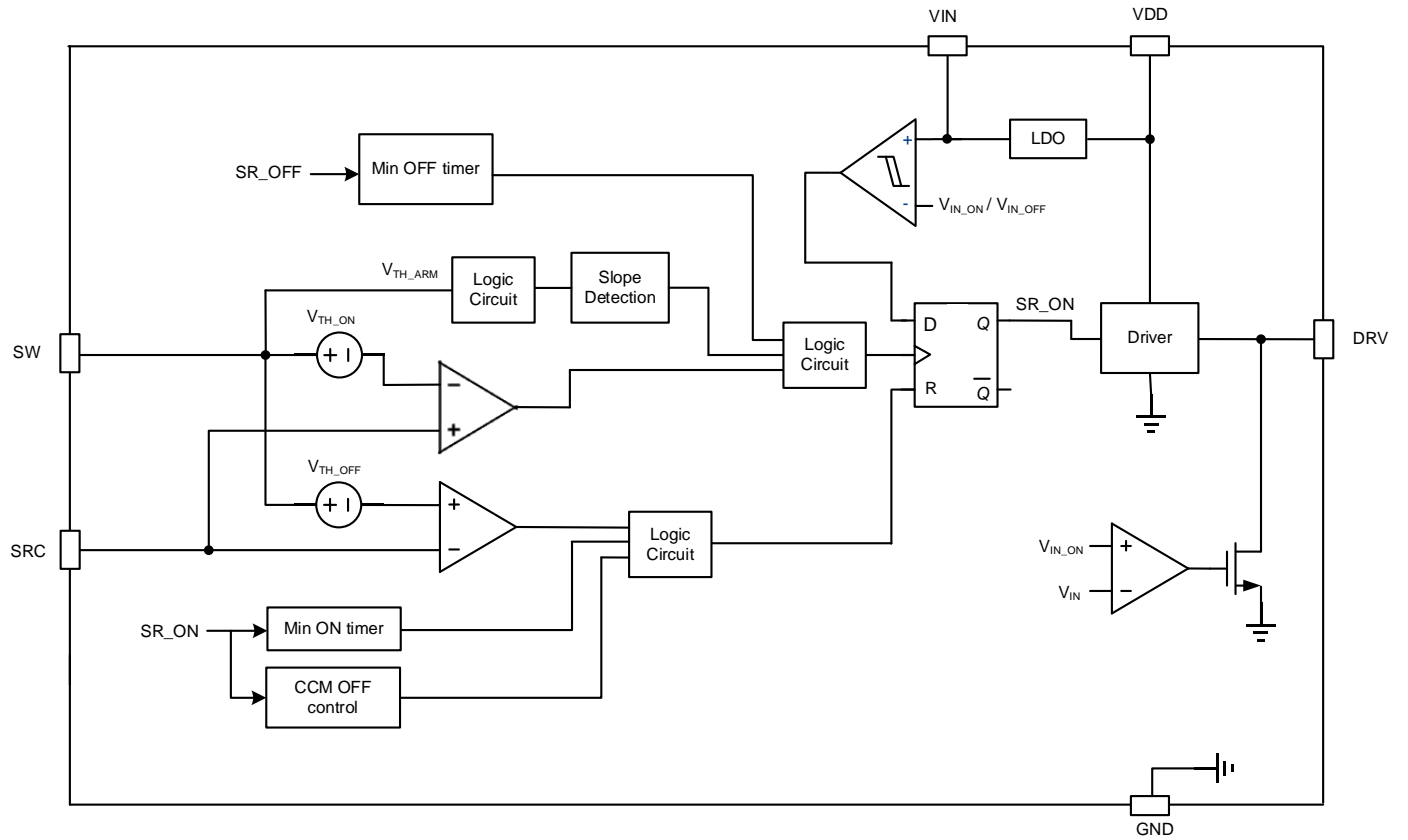

Figure 4. NV9701 Internal Function Block Diagram

Electrical Characteristics

Absolute Maximum Ratings(1)

Stresses exceeding the absolute maximum ratings may damage the device. The device may not function or be operable above the recommended operating conditions and stressing the parts to these levels is not recommended. In addition, extended exposure to stresses above the recommended operating conditions may affect device reliability. The absolute maximum ratings are stress ratings only.

Symbol	Parameter	Min.	Max.	Unit	
VIN	Power Supply Input Pin Voltage	-0.3	28	V	
SW	SW Sense Input Pin Voltage	-1.0	120	V	
VDD	Internal Regulator Output Pin Voltage	-0.3	6.0	V	
DRV	Gate Drive Output Pin Voltage	-0.3	5.5	V	
SRC	Source Sense Input Pin Voltage	-0.3	5.5	V	
TJ	Operating Junction Temperature	-40	150	°C	
TSTG	Storage Temperature Range	-60	150	°C	
TL	Lead Soldering Temperature	-	260	°C	
ESD	Electrostatic Discharge Capability	Human Body Mode, ANSI/ESDA/JEDEC JS-001-2017	-	2.0	kV
		Charge Device Mode, JED ANSI/ESDA/JEDEC JS-001-2018	-	2.0	kV

Notes (1):

- Stress beyond those listed under absolute maximum ratings may cause permanent damage to the device.
- All voltage values are with respect to the GND pin

Recommended Operating Conditions (2)

The Recommended Operating Conditions table defines the conditions for actual device operation. Recommended operating conditions are specified to ensure optimal performance. Elevation does not recommend exceeding them or designing to Absolute Maximum Ratings.

Symbol	Parameter	Min.	Typ.	Max.	Unit
VIN	Power Supply Input Pin Voltage	3.0	-	24	V
SW	SW Sense Input Pin Voltage	-1.0	-	120	V
VDD	Internal Regulator Output Pin Voltage	-0.3	-	5.5	V
DRV	Gate Drive Output Pin Voltage	-0.3	-	5.5	V
SRC	Source Sense Input Pin Voltage	-0.3	-	5.5	V

Notes (2):

- Functional operation of the device at these or any other conditions beyond those indicated under recommended operating conditions is not implied, exposure to absolute maximum rated conditions of extended periods may affect device reliability. All voltage values are with respect to the normal operation ambient temperature range is from -40°C to +85°C unless otherwise noted.

Electrical Specifications

$V_{IN} (Typ.) = V_{DD} (Typ.) = 5V$, $T_A = -40^{\circ}C$ to $85^{\circ}C$, and $T_A (Typ.) = 25^{\circ}C$, unless otherwise specified.

Parameter		Test Conditions	Min.	Type.	Max.	Unit
Power Supply						
V_{IN_ON}	Turn-on Input Voltage	Vin Rising	2.0	2.2	2.4	V
V_{IN_OFF}	Turn off Input Voltage	Vin Falling	1.8	2.0	2.2	V
I_{IN_GREEN}	Quiescent Current	No DRV Switching	-	200	260	μA
$T_{GREEN}^{(3)}$	Time Threshold for Power Save		-	100	-	μs
$I_{IN_OP_20kHz_5V}$	Operating Current at 5V	$F_{SW} = 20kHz, V_{IN} = 5V$	-	420	520	μA
$I_{IN_OP_100kHz_5V}$	Operating Current at 5V	$F_{SW} = 100kHz, V_{IN} = 5V$	-	450	650	μA
$I_{IN_OP_100kHz_20V}^{(3)}$	Operating Current at 20V	$F_{SW} = 100kHz, V_{IN} = 20V$	-	450	-	μA
V_{DD_ON}	VDD Turn-on Threshold	V_{DD} Rising	2.7	2.9	3.1	V
V_{DD_OFF}	VDD Turn-off Threshold	V_{DD} Falling	2.5	2.7	2.9	V
V_{DD_0A}	VDD Regulation Voltage W/O Load	$V_{IN}=12V$ $I_{VDD}=0A$	4.8	5.0	5.2	V
V_{DD_10mA}	VDD Regulation Voltage with 10mA Load	$V_{IN}=12V$ $I_{VDD}=10mA$	4.7	4.9	5.1	V
SW Pin Sensing						
V_{TH_ON}	Turn-on Threshold		-405	-250	-95	mV
$T_{ON_DLY}^{(3)}$	Turn-on Delay Time		-	10	-	ns
V_{TH_OFF}	Turn-off Threshold		0.01	-	0.8	mV
$T_{OFF_DLY}^{(3)}$	Turn-off Delay Time		-	10	-	ns
SR Gate Control						
T_{ON_MIN}	SR Minimum ON-Time		295	350	405	ns
$T_{ON_MIN_H}$	T_{ON_MIN} at Heavy Load		565	650	735	ns
$T_{OFF_MIN}^{(3)}$	SR Minimum OFF-Time		-	0.8	-	μs
Output Driver						
$V_{OL}^{(3)}$	Driver Output Low Voltage		-	-	0.25	V
V_{OH}	Driver Output High Voltage		4.85	5.0	VDD	V
t_R	DRV Rise Time	$C_L=10nF, DRV=1 \rightarrow 4V$	9	20	31	ns
t_F	DRV Fall Time	$C_L=10nF, DRV=4 \rightarrow 1V$	3	10	15	ns

Note (3):

- Guaranteed by design

Typical Performance Characteristics

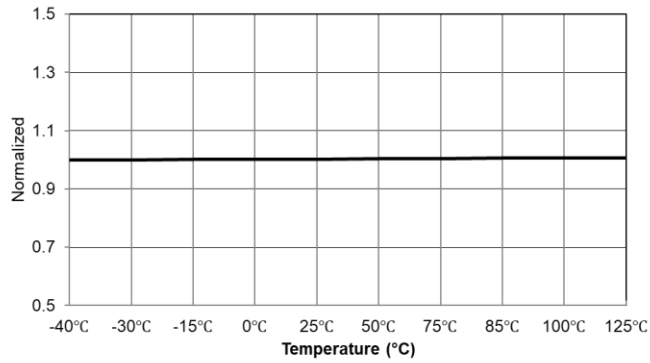

Figure 5 V_{IN_ON}

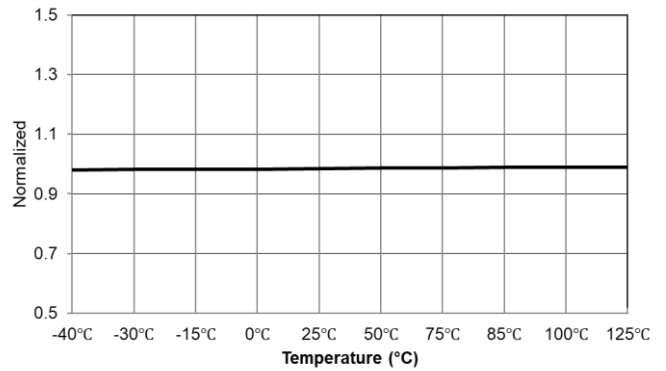

Figure 6 V_{IN_OFF}

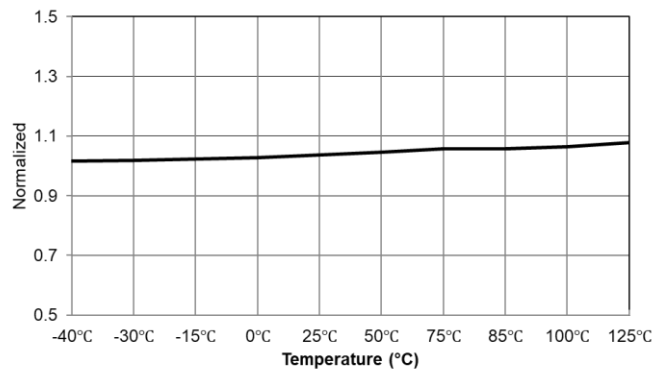

Figure 7 I_{IN_GREEN}

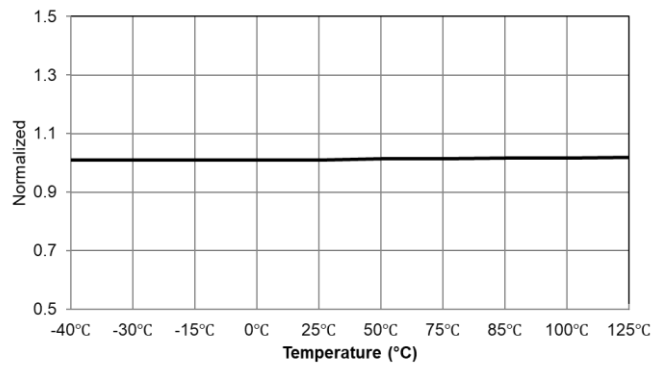

Figure 8 V_{DD_ON}

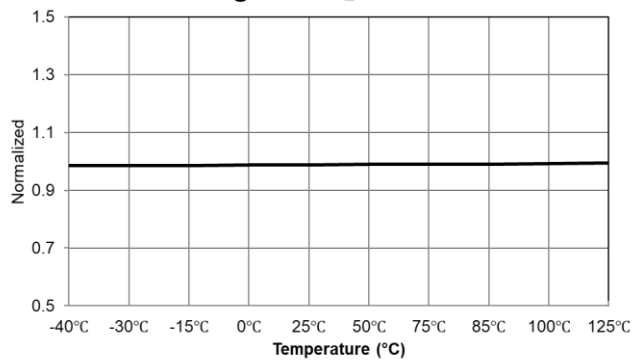

Figure 9 V_{DD_OFF}

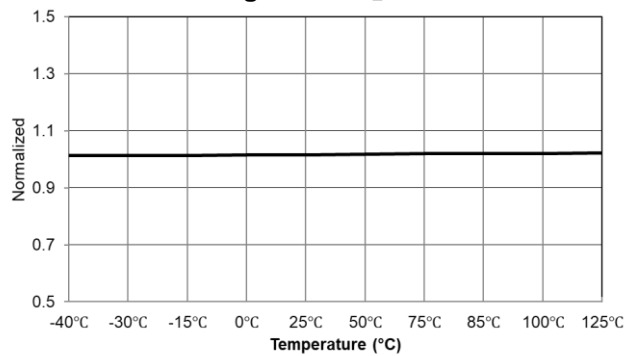

Figure 10 V_{DD_LDO}

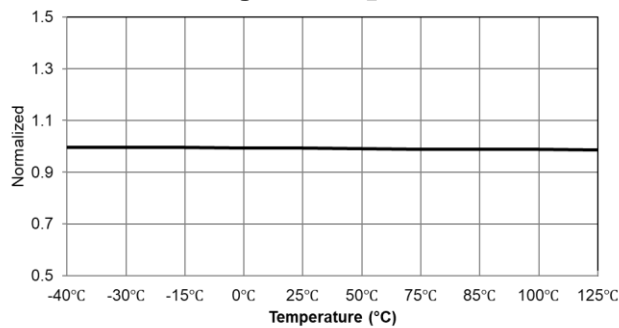

Figure 11 V_{LDO}

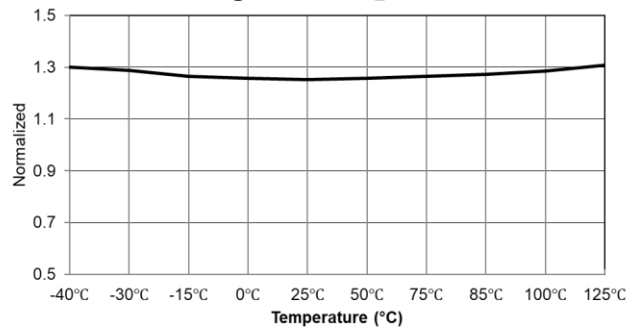

Figure 12 $I_{IN_OP_20kHz_5V}$

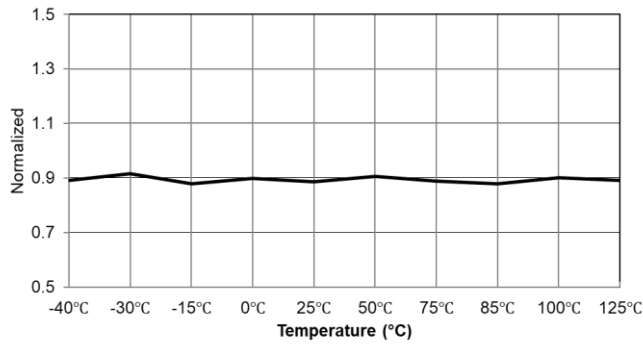

Figure 13 V_{TH_ON}

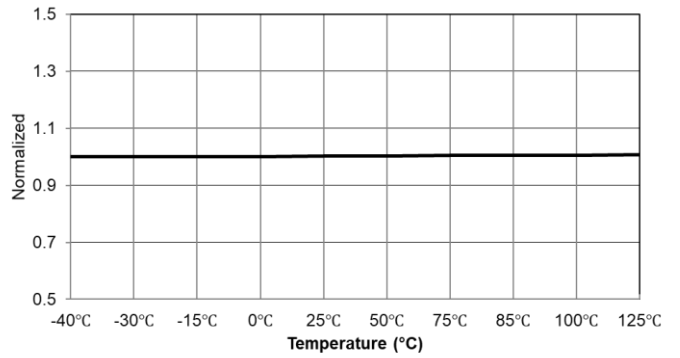

Figure 14 V_{TH_OFF}

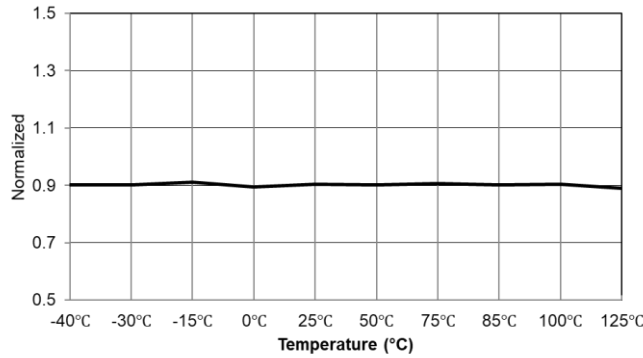

Figure 15 T_{ON_MIN}

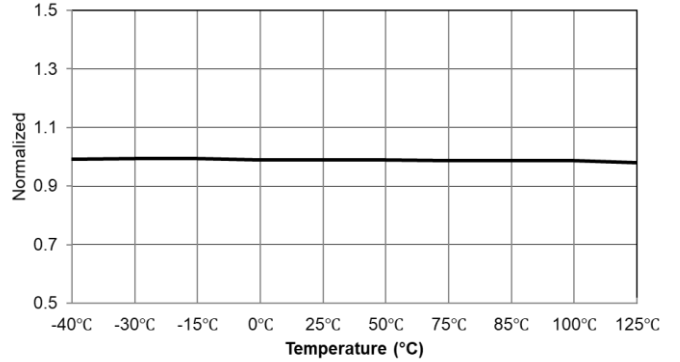

Figure 16 $T_{ON_MIN_H}$

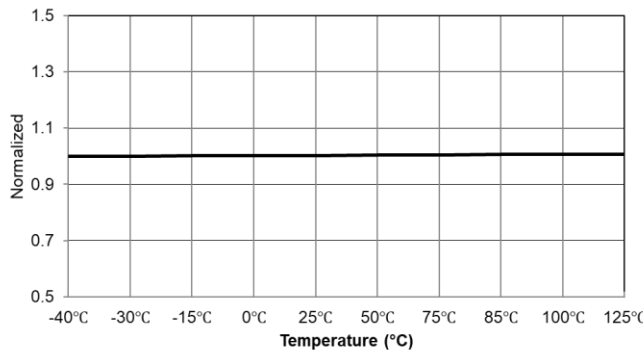

Figure 17 V_{OH}

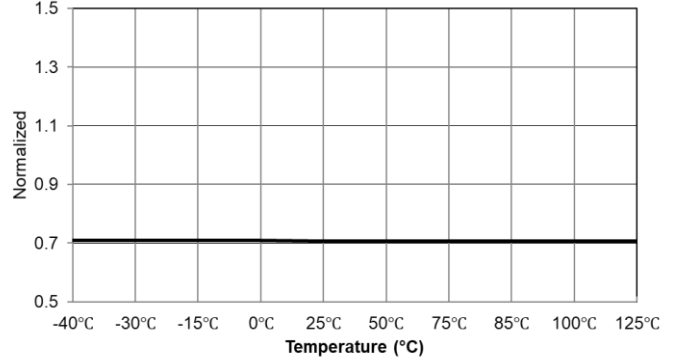

Figure 18 t_R

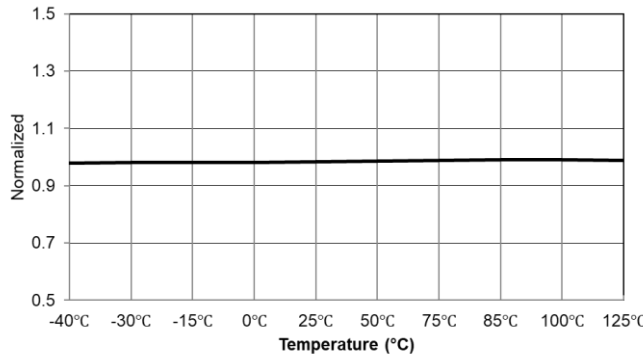

Figure 19 t_F

Typical Performance Characteristics (Continued)

Operating at 65W Flyback Application
VIN= 115VAC, VOUT= 5V, IOUT= 3A



CH1: VDS 20V/div, CH2: DRV 5V/div, CH3: VDD 5V/div

Operating at 65W Flyback Application
VIN= 230VAC, VOUT= 5V, IOUT= 3A



CH1: VDS 20V/div, CH2: DRV 5V/div, CH3: VDD 5V/div

Operating at 65W Flyback Application
VIN= 115VAC, VOUT= 9V, IOUT= 3A



CH1: VDS 20V/div, CH2: DRV 5V/div, CH3: VDD 5V/div

Operating at 65W Flyback Application
VIN= 230VAC, VOUT= 9V, IOUT= 3A



CH1: VDS 20V/div, CH2: DRV 5V/div, CH3: VDD 5V/div

Operating at 65W Flyback Application
VIN= 115VAC, VOUT= 12V, IOUT= 3A



CH1: VDS 20V/div, CH2: DRV 5V/div, CH3: VDD 5V/div

Operating at 65W Flyback Application
VIN= 230VAC, VOUT= 12V, IOUT= 3A



CH1: VDS 20V/div, CH2: DRV 5V/div, CH3: VDD 5V/div

Operating at 65W Flyback Application
VIN= 115VAC, VOUT= 15V, IOU= 3A

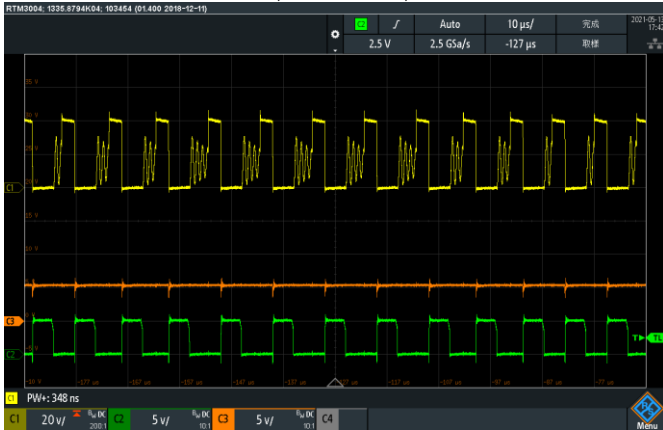

CH1: VDS 20V/div, CH2: DRV 5V/div, CH3: VDD 5V/div

Operating at 65W Flyback Application
VIN= 230VAC, VOUT= 15V, IOU= 3A



CH1: VDS 20V/div, CH2: DRV 5V/div, CH3: VDD 5V/div

Operating at 65W Flyback Application
VIN= 115VAC, VOUT= 20V, IOU= 3.25A

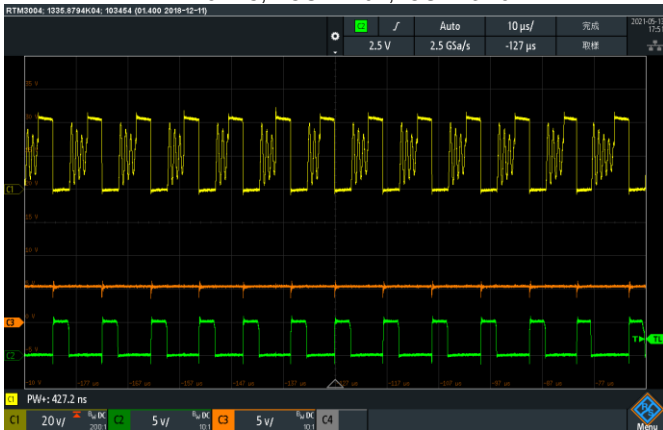

CH1: VDS 20V/div, CH2: DRV 5V/div, CH3: VDD 5V/div

Operating at 65W Flyback Application
VIN= 230VAC, VOUT= 20V, IOU= 3.25A



CH1: VDS 20V/div, CH2: DRV 5V/div, CH3: VDD 5V/div

Detailed Function Description

Operation

NV9701 supports operation in discontinuous conduction mode (DCM), quasi-resonant (QR) and continuous conduction mode (CCM) flyback converters. The control circuitry controls the gate of synchronous rectification (SR) MOSFET on in forward mode and turn the gate off when the SR MOSFET current drops to certain value.

VDD Power Supply

VDD is the supply power for the NV9701, a bypass ceramic (typical 1 μ F) capacitor should be put closely from VDD to GND to guarantee the normal operation.

During startup, when V_{IN} rises above V_{IN_ON} (2.2V) and VDD rises to V_{DD_ON} (2.9V), NV9701 starts to operate according to its internal logic. When VDD falls below V_{DD_OFF} (2.7V) or V_{IN} falls below V_{IN_OFF} (2.0V), then NV9701 stops working right away

SR Gate Turn-On Control

As shown in Figure 20, the turn-on of SR GATE is active when the SW sense voltage is lower than turn on threshold V_{TH_ON} (-250mV). To prevent the mis-trigger turn-on of SR MOSFET, a minimum off time T_{OFF_MIN} is used after SR MOSFET is turned off.

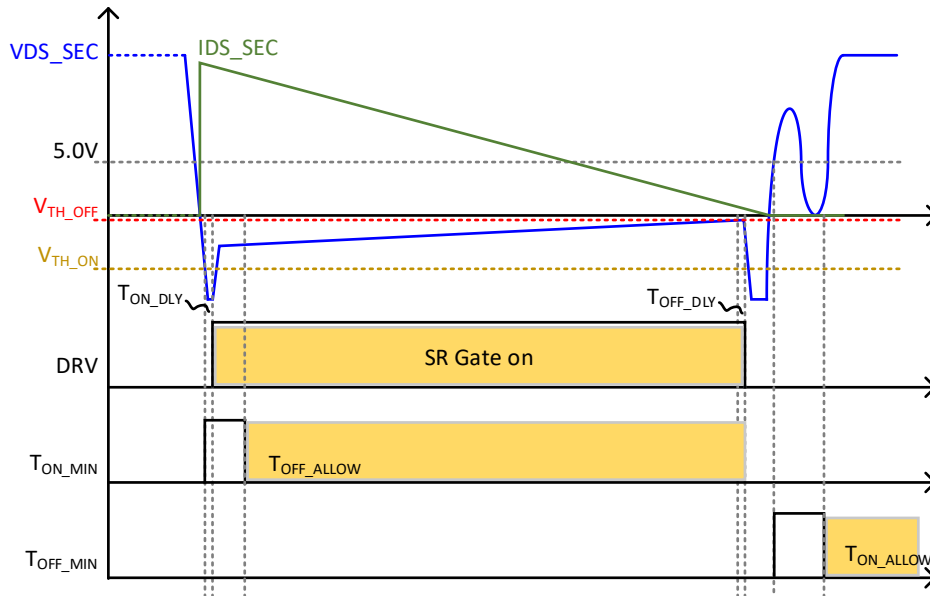

Figure 20. SR Turn-On Control Sequence

SR Gate Turn-Off Control

NV9701 will detect the SW voltage, when it is higher than V_{TH_OFF} (0mV), the GATE will be turned off.

PCB Layout Guidelines

Optimized PCB layout is key for stable operation. Please refer to following layout guidelines to design your platform.

Sensing Loop for VSW and VSRC

- Make the sensing path of SW, SRC as short to Drain and Source of SR MOSFET as possible.
- Make two independent routing trace to Drain and Source of SR MOSFET directly.
- Make NV9701 device out of the power loop to prevent interrupting from the switching noise.

SR Gate Driver Loop

- Make VDRV routing trace far away from the switching point (such as Drain and Source of SR MOSFET).
- Minimize the gate driver loop as short as possible to prevent the interference of noise.
- Do not make VDRV routing trace on the other side of VSW and VSRC.

Power Supply Loop

- Put a low ESR and low ESL decoupling ceramic capacitor from VDD to GND as close to NV9701 as possible for stable power supply. Figure shows a layout example of a single layer with PowerPAK/SO-8 package SR MOSFET with SR MOSFET put in low side for reference.
- In the PCB layout, RSNUB and CSNUB are the RC snubber network for the SR MOSFET. The VDD decoupling capacitor (CVDD) is placed close to VDD GND. The sensing loop (SRC, SW to the Source and Drain of SR MOSFET) is minimized and keep away from the switching power loop.

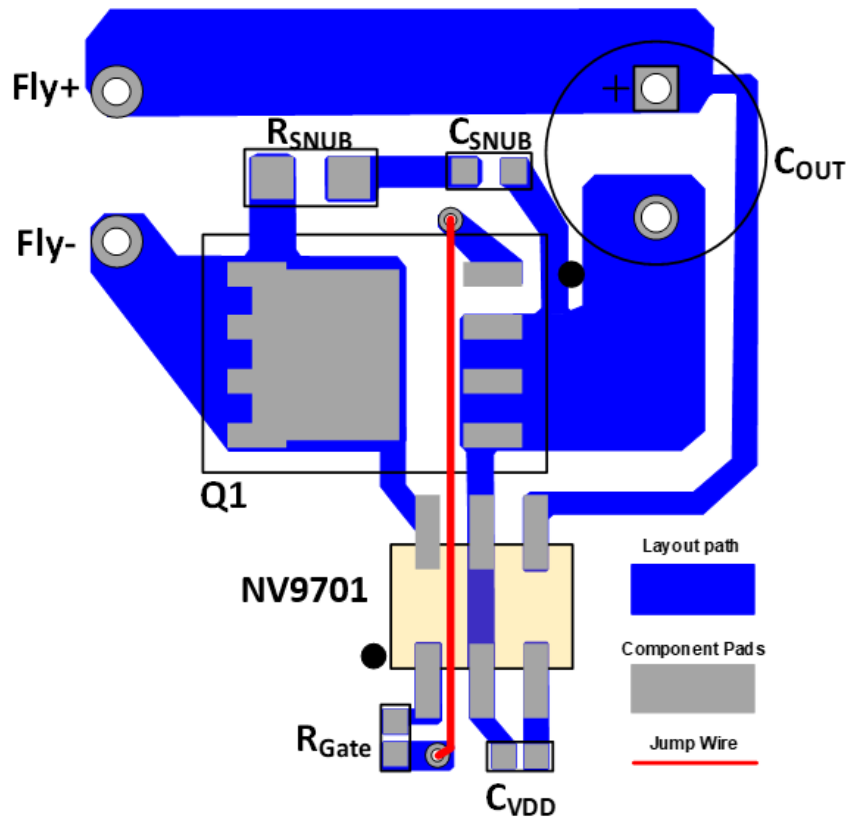
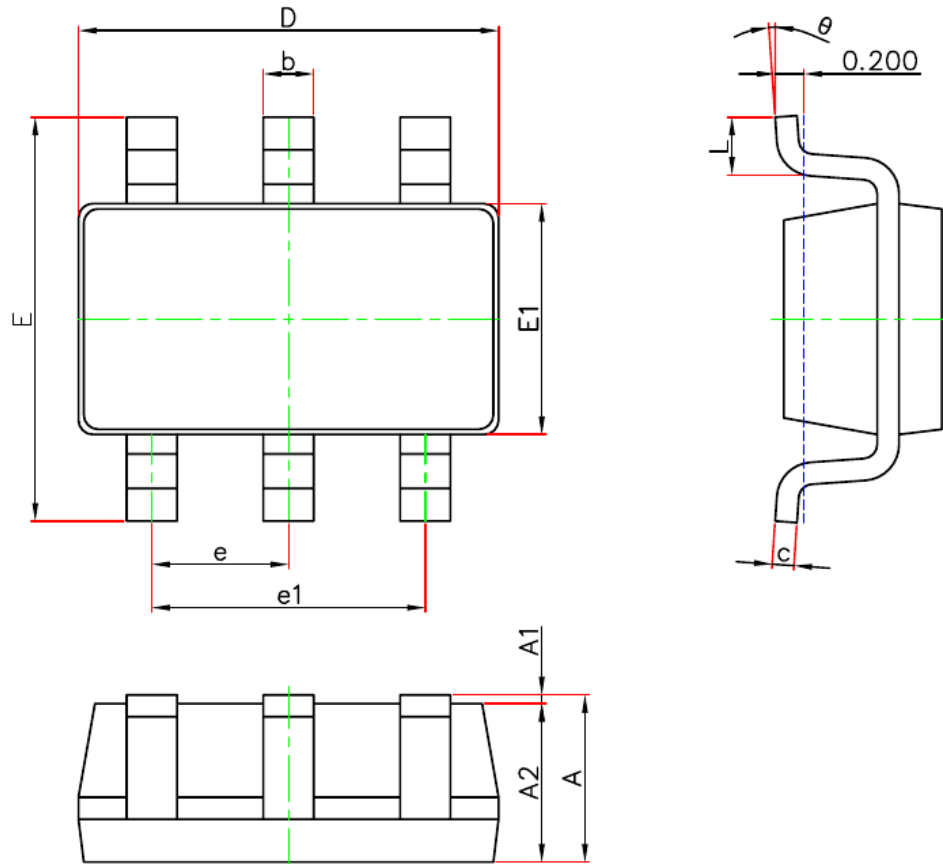

Figure 21. Layout with PowerPAK/SO-8 SR MOSFET

Package Dimensions

SOT-23-6L(12R) PACKAGE OUTLINE DIMENSIONS



Symbol	Dimensions In Millimeters		Dimensions In Inches	
	Min.	Max.	Min.	Max.
A	1.050	1.250	0.041	0.049
A1	0.000	0.100	0.000	0.004
A2	1.050	1.150	0.041	0.045
b	0.300	0.500	0.012	0.020
c	0.100	0.200	0.004	0.008
D	2.820	3.020	0.111	0.119
E1	1.500	1.700	0.059	0.067
E	2.650	2.950	0.104	0.116
e	0.950(BSC)		0.037(BSC)	
e1	1.800	2.000	0.071	0.079
L	0.300	0.600	0.012	0.024
θ	0°	8°	0°	8°

Tape and Reel Information

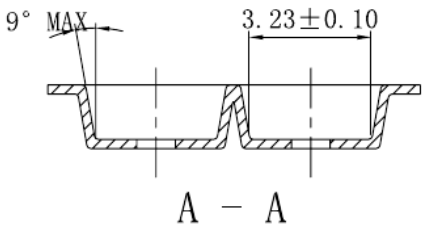
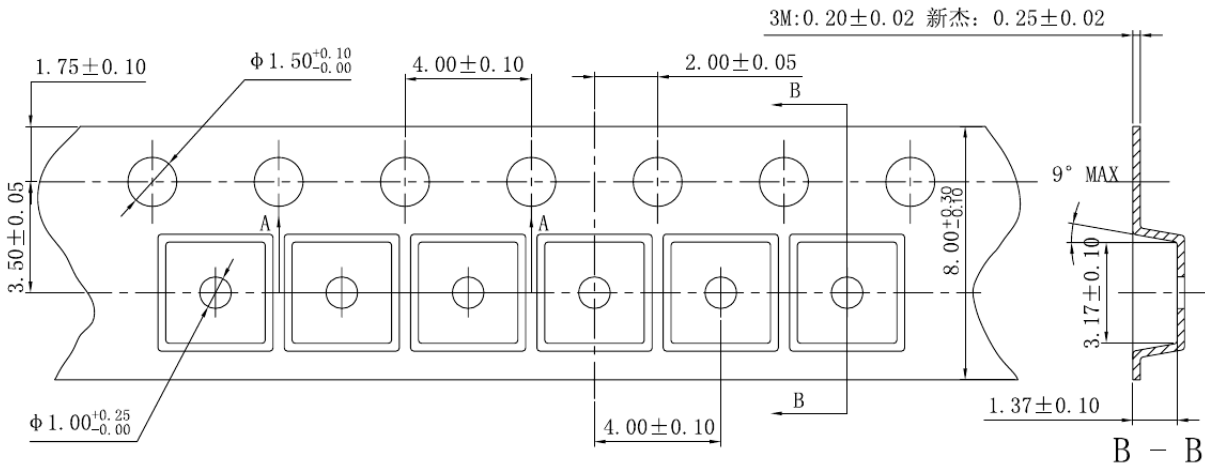
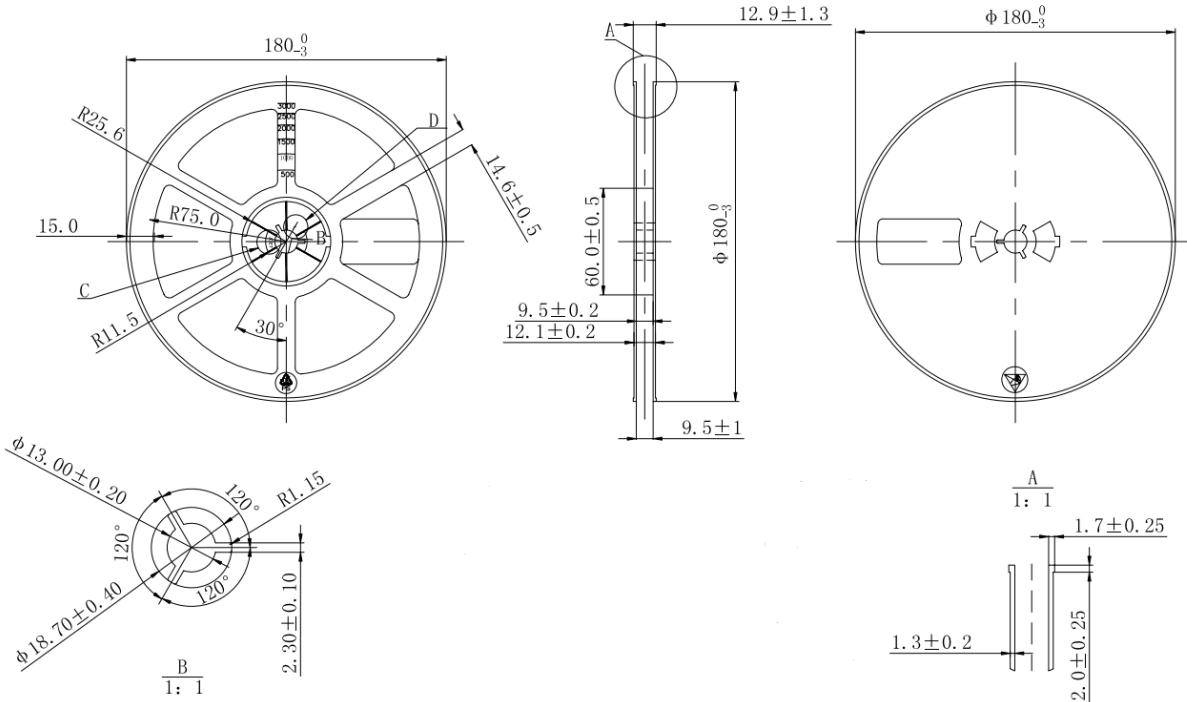

20-Year Limited Product Warranty

The 20-year limited warranty applies to all packaged Navitas GaNFast Power ICs, GaNFast HFQR Controllers, and Controller ICs in mass production, subject to the terms and conditions of, Navitas' express limited product warranty, available at <https://navitassemi.com/terms-conditions>. The warranted specifications include only the MIN and MAX values only listed in Absolute Maximum Ratings and Electrical Characteristics sections of this datasheet. Typical (TYP) values or other specifications are not warranted.



Revision History

Date	Status	Notes
Feb. 15, 2023	PRELIMINARY	First publication
Feb. 24, 2023	PRELIMINARY	Second publication

Additional Information

DISCLAIMER Navitas Semiconductor (Navitas) reserves the right to modify the products and/or specifications described herein at any time and at Navitas' sole discretion. All information in this document, including descriptions of product features and performance, is subject to change without notice. Performance specifications and the operating parameters of the described products are determined in the independent state and are not guaranteed to perform the same way when installed in customer products. The information contained herein is provided without representation or warranty of any kind, whether express or implied. This document is presented only as a guide and does not convey any license under intellectual property rights of Navitas or any third parties. Navitas' products are not intended for use in applications involving extreme environmental conditions or in life support systems. [Terms and Conditions](#).

Navitas Semiconductor, Navitas, GaNFast, GaNSense and associated logos are registered trademarks of Navitas.

Copyright ©2023 Navitas Semiconductor. All rights reserved

Contact info@navitassemi.com

